



TOP)A)K)U)S)T)I)K) 

INSPIRED LISTENING

EDITION 2019/2020



## BEAUTY MEETS PERFORMANCE

Every room engages and impacts our senses. The first impression we gain is visual: we take in the room's design. Then, at a more subconscious level and after some delay, we become aware of its acoustics. TOPAKUSTIK and TOPPERFO will meet all your expectations in terms of design and acoustics: products that deliver inspired listening!

You'll find all our products in this brochure: our tried-and-tested TOPAKUSTIK range with its characteristic grooving as well as TOPPERFO with even smaller perforations so the sound absorption function becomes virtually invisible. Almost fifty photographs from ten different countries show the convincing results of the successful use of our products.

TOPAKUSTIK is far more than a mere brand name. Nearly one hundred individuals work in our planning and production departments, and our team of experienced specialists are at your disposal for advisory services, sales and distribution.

We're looking forward to working on your project!

Georg Hegglin, CEO

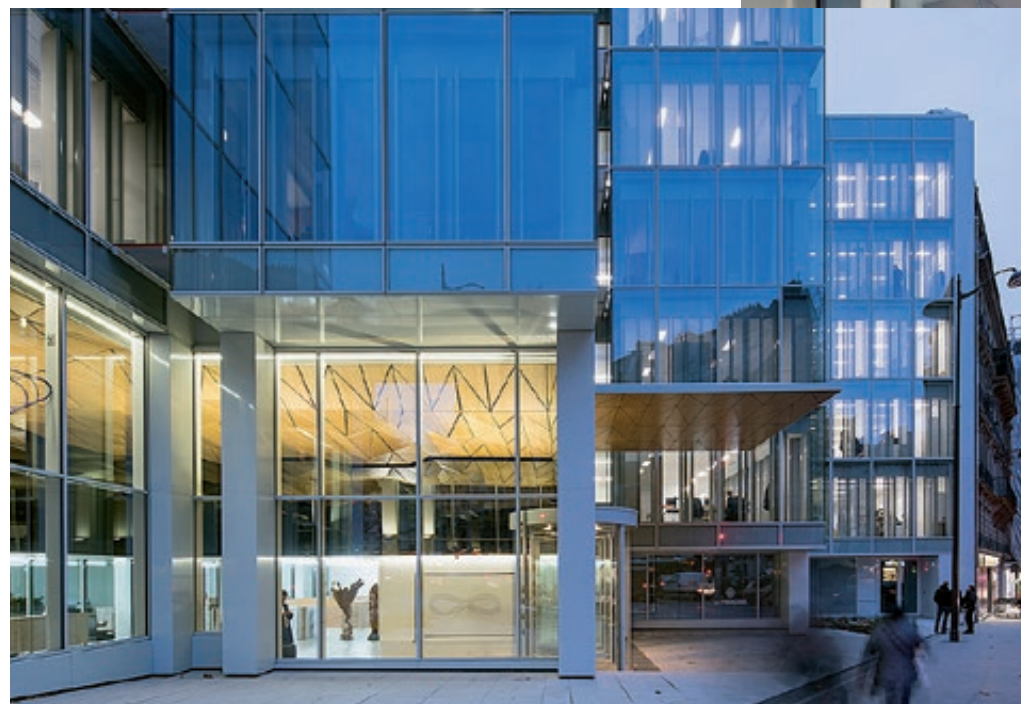

HQ "La Française", Boulevard Raspail, Paris  
Architect: Franklin Azzi, Paris – Photo: Luc Boegly, Paris  
Product: TOPPERFO Micro 2/2/0.5, Oak veneered

This ceiling, consisting entirely of triangular shapes, adds that special extra touch to the reception area at the headquarters of finance group "La Française" on Boulevard Raspail in Paris.

Over 30 different triangles were first produced in our factory and then the ready-to-install elements were quickly and easily mounted on site.



## CONTENTS

## THE REFINED ACOUSTIC SYSTEM TOP(A)K(U)S(T)I(K)<sup>®</sup>

Available in planks with a tongue and groove connection (plank width = 128 mm\*) for joint-free surface appearance or in panels (panel width = 300 – 1200 mm) for removable or fixed ceilings, walls or cabinet fronts.

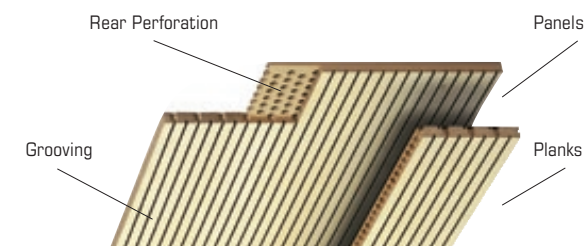

## TECHNICAL INFORMATION

## PERFORATION AS REQUIRED TOP(P)E(R)F(O)<sup>®</sup>

A wide range of perforations for wall and ceiling finishes. Conventional M-Perforation, discrete T-Perforation or micro perforations (Clou + Micro). Available in panels and planks.

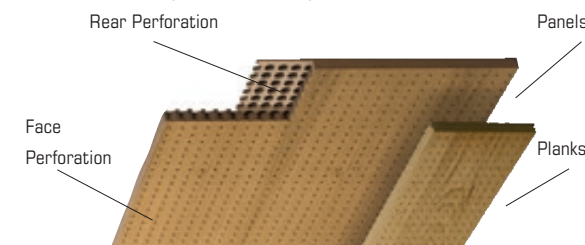

**NEW!**

= new Products

**!** The information in boxes is very important and should be read carefully !

\* 1 INCH = 25.4 mm e.q. 128 mm = 5.04"

4/5	BASICS
6/7	NARROW GROOVES
8/9	MEDIUM-SIZED GROOVES
10/11	WIDE GROOVES
14	TOPAKUSTIK Special grooves
15	TOPAKUSTIK-R <b>NEW!</b>
16	TOPAKUSTIK ARIA-Plus
17	TOPAKUSTIK ARIA-Pure <b>NEW!</b>
<hr/>	
18/19	CORE MATERIAL
20/21	SURFACES-ECO <b>NEW!</b>
22/23	EDGES + DETAILS
24/25	MOUNTING
<hr/>	
28/29	BASICS
30/31	TOPPERFO-Micro <b>NEW!</b>
32/33	TOPPERFO-Clou
34/35	TOPPERFO-T
36/37	TOPPERFO-M
38	TOPPERFO Special
39	TOPPERFO Graphic
42	TOPPERFO Planks <b>NEW!</b>
<hr/>	
43	SIXTY-SYSTEM (2x2 PANELS)
44	CABINETS FRONTS + DOORS
45	SHAPES
46	GYMNASIA
47	SWIMMING POOLS
48/49	NH QUALITY + SERVICE



# TOPAKUSTIK®

The refined acoustic system for wall and ceiling finishes. Many different groove patterns are available. Narrow spaced grooves appear as a textured surface (6/2, 8/3, 9/2) – wider spaced grooves can be seen individually by the eyes (12/4, 13/3, 14/2, 19/2, 28/4). Thanks to the rear perforation pattern, the core panel remains structurally intact allowing for cutouts (programmed or field performed) to address penetrations required for lighting, HVAC and sprinkler systems.

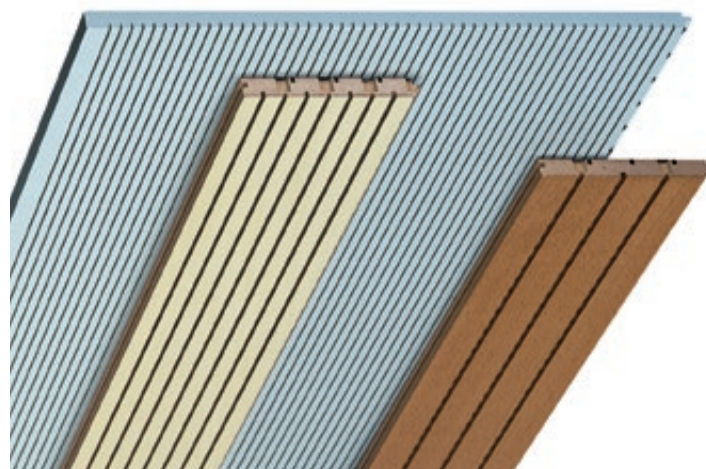

Please note: Walls finished with lighter veneers (maple, birch) or lighter paint (white) can have a visually disturbing effect (flickering-Moiré Pattern) from the light to dark contrast from the face surface to the grooves. In these areas we recommend using the TOPAKUSTIK designs with 2mm wide groove e.g. type 9/2 or 14/2 or 19/2 and/or using darker veneers or darker paint colours to minimize this effect.

## THE ACOUSTIC SYSTEM

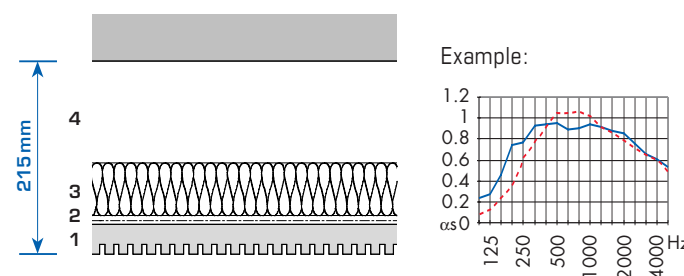
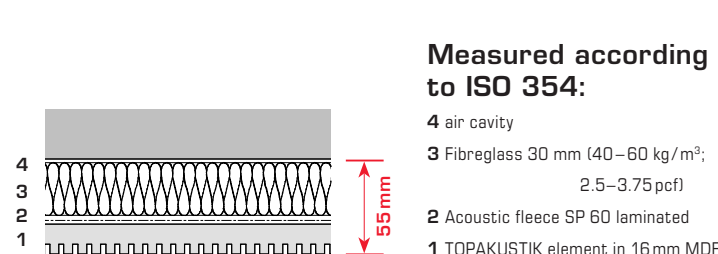

All TOPAKUSTIK types are available with M and T perforations on the rear. This makes it possible for acousticians to match the TOPAKUSTIK surface treatment with the required absorption. The absorption coefficients stated in this brochure were measured according to the ISO 354 standard and are set up as described above. Additional absorption coefficients with other cavity depths and other porous materials in the air cavity (e.g. only fleece, melamine resin foam, etc.) are listed in the TOPAKUSTIK/TOPPERFO sound absorption document.

The sound absorption of our products is measured in a reverberation room in accordance with DIN ISO 354:1985. This provides the α<sub>s</sub> (alpha) values either listed in tabular form or plotted on a chart. You can find such charts in the descriptions of the individual products. The α<sub>w</sub> value given in the table is the weighted sound absorption level that is calculated using a standardized method. The classification into Euroclasses A, B, C, D and E is calculated and derived from the α<sub>w</sub> value (A = highest absorption capacity). The NRC (noise reduction coefficient) is the value specified according to the US standard ASTM C423. Behind each α<sub>w</sub> value are the letters L, M and/or H to indicate if the sound absorption of the product is greater than 0.25 in a specific frequency range. L is for low or 250 Hz, M is for mid or 500 or 1000 Hz, and H is for high or 2000 or 4000 Hz.

**M-Perforation:** For absorption in the medium to high frequency range. TOPAKUSTIK products with M-Perforation are suited for applications in which the reverberation time is to be lowered across a broad frequency band.

**T-Perforation:** For absorption in the low to medium frequency range. The high absorption in the low-frequency range is based on the combination of small holes on the visible side and larger holes on the rear.

**Reflectors:** TOPAKUSTIK products can also be used as reflectors by eliminating the perforations on the rear surface. The absorption figures are then equivalent to those of a standard reflecting panel.

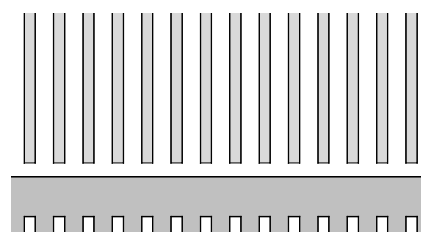
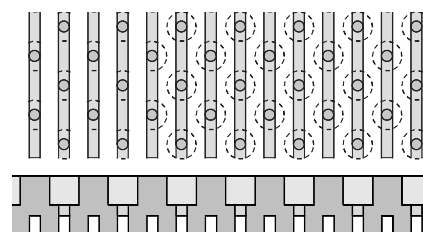
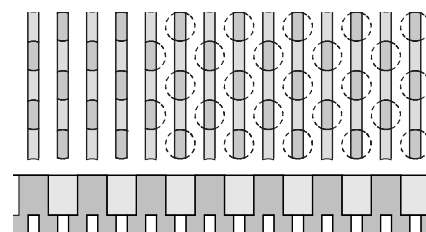

## DIMENSIONS AND MATERIALS

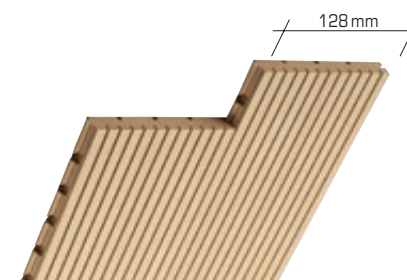

### Planks

Thanks to the precise tongue and groove connection, planks result in an attractive surface with a joint-free appearance, because the connecting joint matches the dimension of the grooves. The planks permit simple and flexible assembly. They can be installed by stapling to a timber batten or clamping to a T-bar with TOPAKUSTIK clips. (Assembly p. 24)

not fire rated D-s2,d0 (DIN B2)			fire retardant B-s2,d0 (DIN B1)			non-flammable	
Paint 16mm	Wood Veneer 17mm	Melamine 16mm	Paint 16mm	Wood Veneer 17mm	Melamine 16mm	Paint 16mm	Wood Veneer 17mm
Standard							
2780 × 128	2780 × 128 3640 × 128	2780 × 128	2780 × 128	2780 × 128 3640 × 128	2780 × 128	2540 × 128 3080 × 128	2540 × 128 3080 × 128
4080 × 128		4080 × 128	4080 × 128		4080 × 128		
custom lengths are also available							

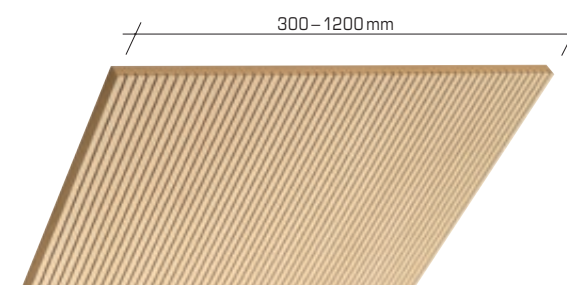

### Panels

Panels are used for removable or fixed ceilings and walls with visible joints. Panels can be provided with a number of different edges (p. 22) and are also suited for cabinet fronts and room dividers.

not fire rated D-s2,d0 (DIN B2)			fire retardant B-s2,d0 (DIN B1)			non-flammable	
Paint 16mm	Wood Veneer 17mm	Melamine 16mm	Paint 16mm	Wood Veneer 17mm	Melamine 16mm	Paint 16mm	Wood Veneer 17mm
max.							
4080 × 1216	3640 × 1216	4080 × 1216	4080 × 1216	3640 × 1216	4080 × 1216	3080 × 1216	3080 × 1216
ideal = means optimal use of MDF core – custom lengths are also available							
2040 × 992/640	2040 × 992/640	2040 × 992/640	2040 × 992/640	2040 × 992/640	2040 × 992/640	1540 × 608	1540 × 608
2780 × 992/640	2780 × 992/640	2780 × 992/640	2780 × 992/640	2780 × 992/640	2780 × 992/640	2540 × 608	2540 × 608
3640 × 640	3640 × 640			3640 × 640		3080 × 608	3080 × 608

Fire category – more information page 18/19

page 20/21

Date 2019 – please check the current dimensions on [www.topakustik.ch](http://www.topakustik.ch)



### Interrupted grooves:

With panels, the grooves can be interrupted. The distance can be chosen as required.



TOP(A)K(U)S(T)I(K)®

NARROW GROOVING  
CENTER-TO-CENTER  
DISTANCE = 8mm or 10.66mm

This grooving is less «visible» as the interaction of light and shadow occurs regularly due to the close spacing of the grooves, thus creating a 2-dimensional effect. The narrow grooves require perfect assembly, as even the smallest differences in the surface are visible.

See page 5 for dimensions and materials  
See page 20/21 for surfaces

Type 6/2 M or T

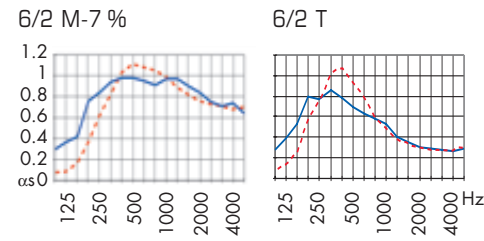
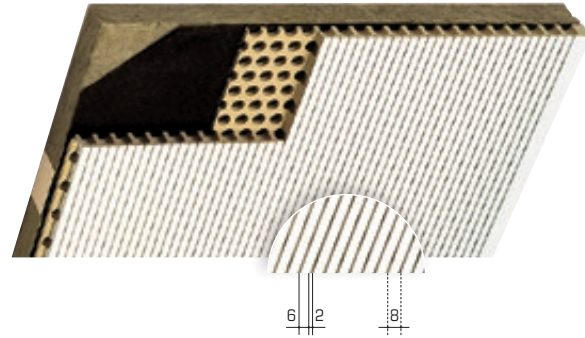

Type 8/3 M

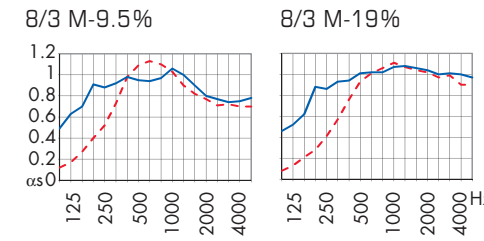
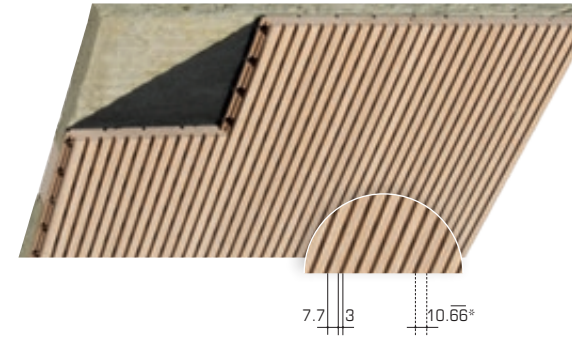

Type 9/2 M

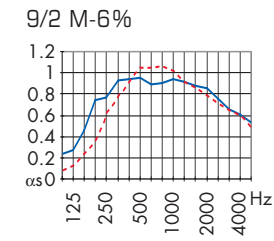
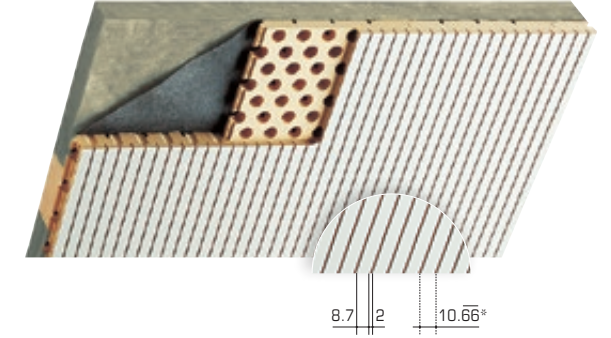

Type 8/3 + 9/2:  
please respect  
10.66mm for  
planning

TOTAL THICKNESS  
— ≈ 215 mm  
- - - ≈ 55 mm  
More information Page 4

1 LVM, Münster DE – Architect: HPP Düsseldorf, DE – Photo: HGEsch/Hennef, Blankenberg DE 2 Pilatus Businesscenter, CH 3 AVM Computersysteme, Berlin DE – Architect: Trucks Architekten, Berlin DE

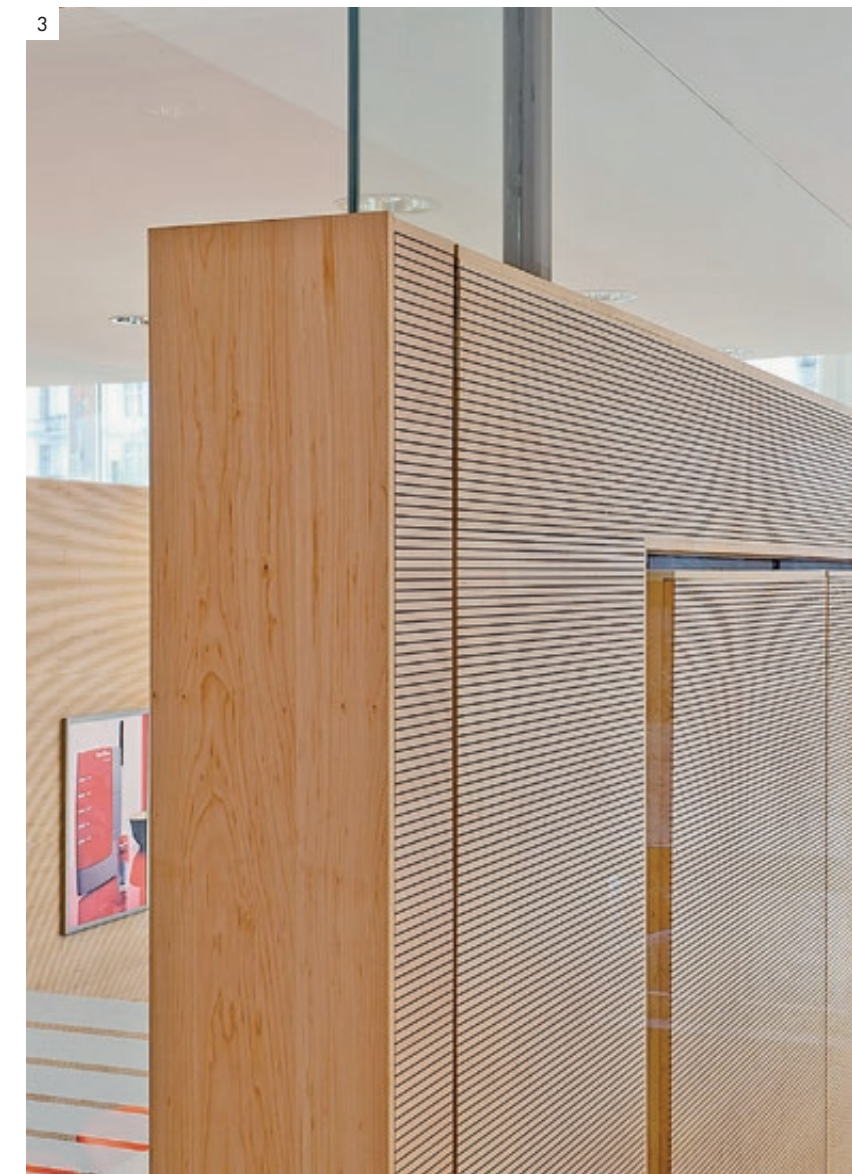



TOP(A)K(U)S(T)I(K)<sup>®</sup>

MEDIUM-SIZED  
GROOVING  
CENTER-TO-CENTER  
DISTANCE = 16 mm

The most popular TOPAKUSTIK types. High sound absorption combined with easy assembly. The grooving is visible even from a long distance.

See page 5 for dimensions and materials  
See page 20/21 for surfaces

Type 14/2 M

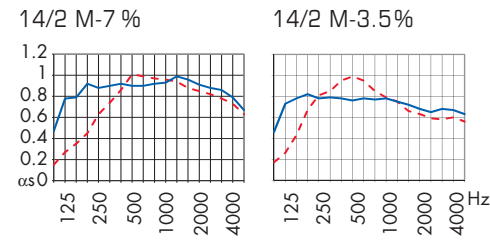
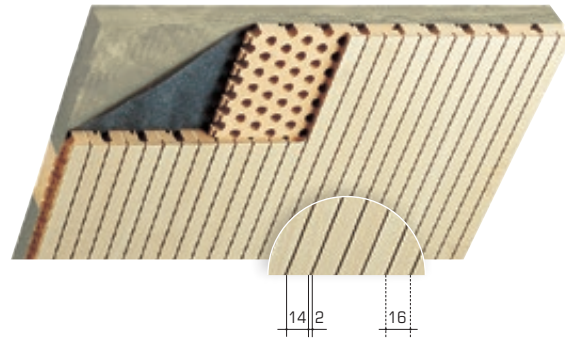

$\alpha_w$	Euro	NRC	$\alpha_w$	Euro	NRC
0.90	A	0.90	0.75 L	C	0.75
0.85	B	0.85	0.65 LM	C	0.80

TOTAL THICKNESS  
— ≈ 215 mm  
- - - ≈ 55 mm  
More information Page 4

Type 13/3 M or T

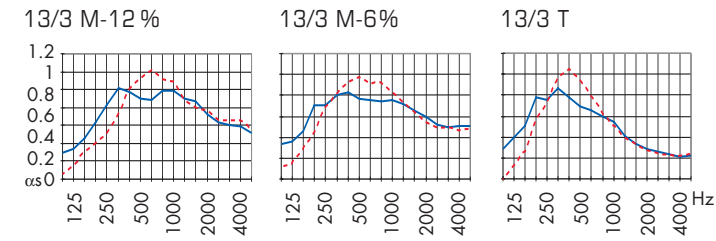
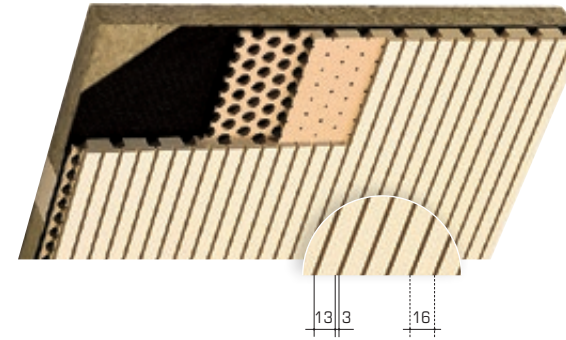

$\alpha_w$	Euro	NRC	$\alpha_w$	Euro	NRC	$\alpha_w$	Euro	NRC
0.75 L	C	0.85	0.65 L	C	0.70	0.35 LM	D	0.55
0.75 M	C	0.90	0.60 LM	C	0.75	0.35 LM	D	0.60

Type 12/4 M or T

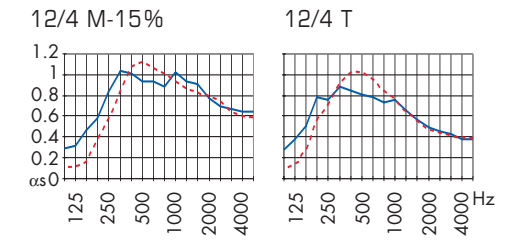
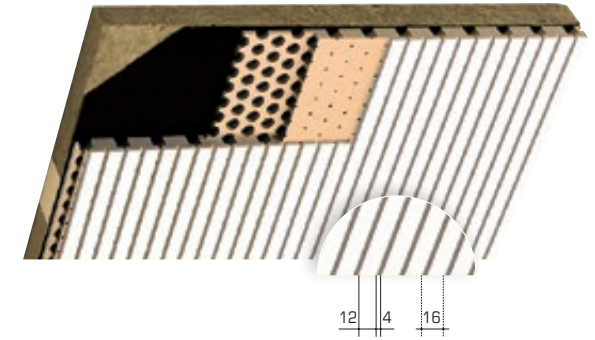

$\alpha_w$	Euro	NRC	$\alpha_w$	Euro	NRC
0.80 M	B	0.85	0.63 L	C	0.70
0.80	B	0.90	0.57 LM	C	0.75

4 AWZ, Kleindöttingen CH – Architect: Birchmeier Uhlmann Architekten, Zürich ZH – Photo: Sibylle Kathriner Fotografie, Stans CH 5 Alfred Wegener Institut, Bremerhaven DE – Architect:

Westphal Architekten, Bremen DE – Photo: Anke Müllerklein, Hamburg DE 6 Hôpital Leon Bérard, Lyon

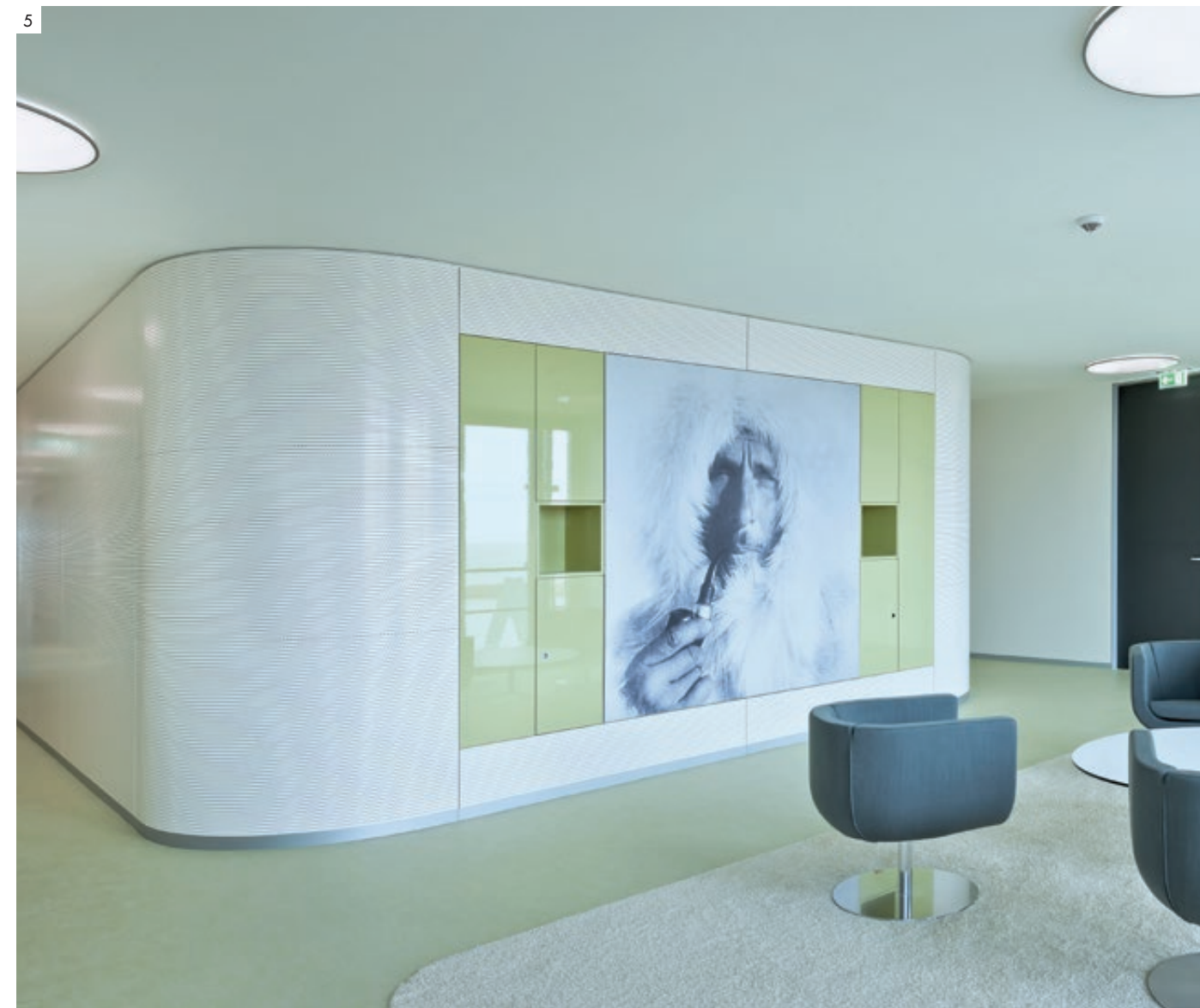



TOP(A)K(U)S(T)I(K)®

WIDE GROOVING  
CENTER-TO-CENTER  
DISTANCE = 21.3 or 32 mm

These grooves are the ideal solution for standard absorption requirements. As with all centre-to-centre distances, the wide grooving comes with 2 mm, 3 mm and 4 mm groove, as laid out in this and page 11.

See page 5 for dimensions and materials  
See page 20/21 for surfaces

Type 19/2 M

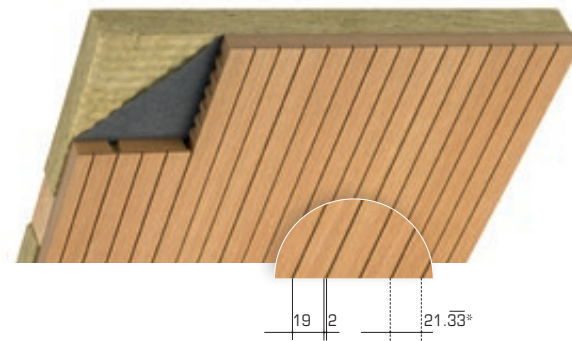

19/2 M-6%

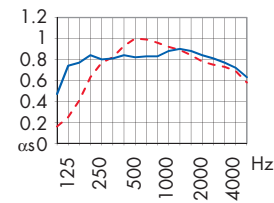

! Type 19/2:  
please respect  
21.33 mm\* for  
planning

TOTAL THICKNESS  
— ≈ 215 mm  
- - - ≈ 55 mm  
More information Page 4

α <sub>w</sub>	Euro	NRC
0.85	B	0.80
0.80	B	0.85

Type 29/3 M & 30/2 M

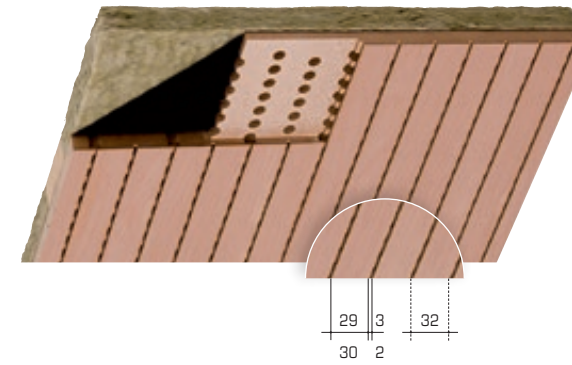

29/3 M-6%

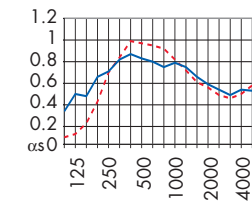

30/2 M-3.5%

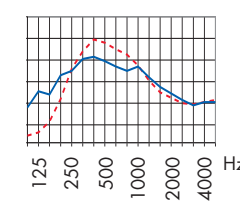

α <sub>w</sub>	Euro	NRC
0.65 L	C	0.75
0.60 LM	C	0.75

α <sub>w</sub>	Euro	NRC
0.55 LM	D	0.70
0.50 LM	D	0.70

Type 28/4 M or T

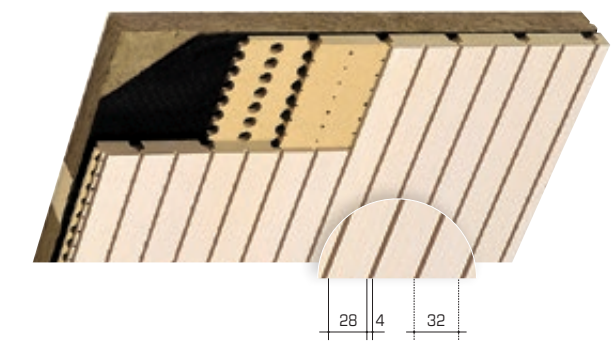

28/4 M-7.5%

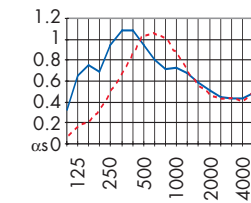

28/4 M-3.75%

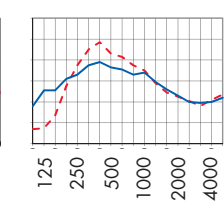

28/4 T

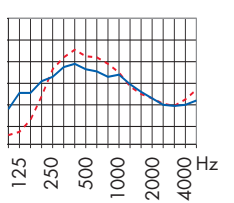

α <sub>w</sub>	Euro	NRC
0.55 LM	D	0.80
0.55 M	D	0.70

α <sub>w</sub>	Euro	NRC
0.5 LM	D	0.65
0.5 LM	D	0.70

α <sub>w</sub>	Euro	NRC
0.25 LM	E	0.40
0.25 LM	E	0.45

7 Landratsamt Ostallgäu, Marktberdorf DE – Architect: Stadtmüller.Burkhardt.Graf Architekten GbR, Kaufbeuren DE – Photo: Klein & Schneider GbR, Mindelheim DE 8 University of Sydney AU –

Architect: Kannfinch, Sydney AU – Photo: Euroline Pty Ltd., Auburn AU 9 Wheaton High School, USA – Architect: Grimm + Parkins Architects, USA – Photo: Kevin Burns, USA





## COMPOSING A MASTERPIECE

Should you require each panel to be a different shape or a standard solution is preferred – we can manufacture both. For products that are easier to use such as our TOPAKUSTIK planks, you can decide how the surface will look. You can choose any RAL/NCS colour, any commercially available wood veneer or perhaps you prefer a decorative melamine resin finish, with many being available. Whatever your choice, we'll be delighted to play our part in composing your «MASTERPIECE».



Aviva HQ, St. Helens Tower, London GB  
Architect: TTSP Archi. + Design, London GB – Photo: Nick Guttridge, London GB  
Product: TOPAKUSTIK Planks 14/2 M-7%

This auditorium is naturally dominated by the gigantic screen that extends across its entire front. But all the other walls are covered with TOPAKUSTIK planks to ensure that the acoustics are perfect! Another benefit: the warmth emanated by the genuine wood veneer provides a pleasant counterbalance to the otherwise cool interior.





TOP(A)K(U)S(T)I(K)<sup>®</sup>

SPECIAL GROOVES

Would you like the grooving to be something special?  
 How about our type Caro, or the type HR 9/2 M with its semicircular grooves? Many more variations are possible: for instance, the distance between the grooves can be widened to 64 or 96 mm. Absorption values are available.

Caro M

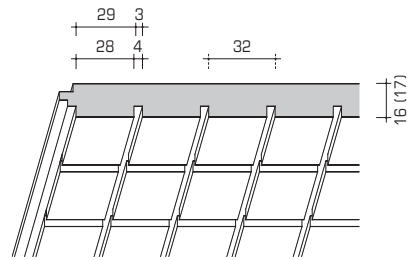
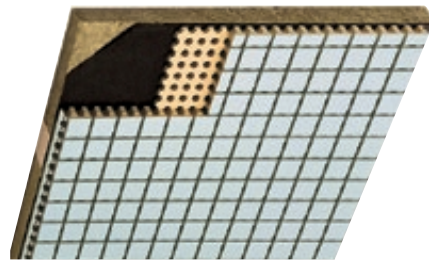

HR 9/2 M

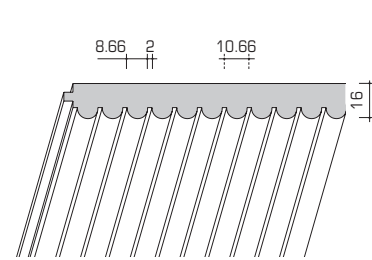
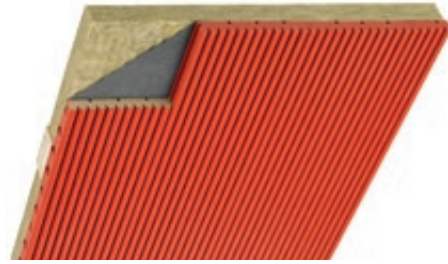

Caro 29/3 M	α w	Euro	NRC
215 mm	0.85	B	0.85
55 mm	0.80 M	B	0.85

HR 9/2 M	α w	Euro	NRC
215 mm	0.75 L	C	0.80
55 mm	0.75 M	C	0.85

Surface:	(only paint)	(only paint)
Grooving:	28/4 M + 29/3 M	HR 9/2 M
Fire category core panel:	fire retardant B-s2,d0 (US = Class A) and standard MDF D-s2,d0 (US = Class C)	
Formats/Dimensions:	Panels max. 3640 x 1250 mm	Planks max. 3800 x 128 mm

TOP(A)K(U)S(T)I(K)<sup>®</sup>

TOPAKUSTIK-R **NEW!**

Type R has an irregular grooving pattern that repeats itself systemically every 128 mm. Two (Type Duo) or even three (Type Trio) differently grooved planks increase the irregularity, especially when its assembly happens randomly. On panels, the grooving repeats itself only every 592 mm, which would not be noticed.

RL3 -7,4%	α w	Euro	NRC
226 mm	0.79	B	0.80
66 mm	0.82	C	0.85

RL4 -9,4%	α w	Euro	NRC
226 mm	0.80	B	0.80
66 mm	0.80	B	0.85

RP4 -10,7%	α w	Euro	NRC
216 mm	0.85	B	0.80
56 mm	0.85	B	0.85

R-Planks

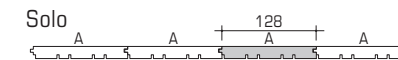
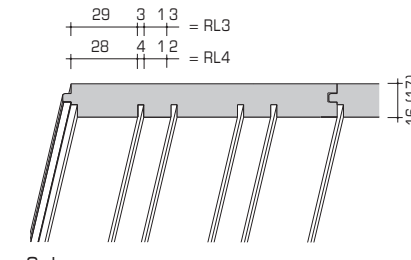

R-Panels

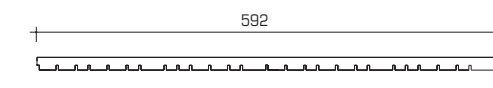
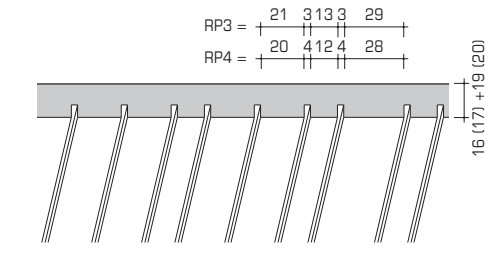

10 Theater Agora, Lelystad NL – Architect: UNStudio, Amsterdam NL 11 EPFL, Lausanne CH – Architecte: Richter-Dahl Rocha & Associés architectes SA, Lausanne CH – Photo: EPFL, Lausanne

12 Family Lodge + Spa, Melchsee-Fruyt CH – Architect: Architekturwerk AG, Sarnen CH – Photo: Sibylle Kahriner Fotografie, Stans CH



10



11



12



TOP(A)K(U)S(T)I(K)<sup>®</sup>

ARIA-Plus

The perforation is barely visible thanks to the deep grooving and the black MDF board. The grooves create the effect of individual bars. The product can be promoted as no added Formaldehyde.

Core board size	Topperfo panels	Topakustik planks
4080 × 2050 mm	ideal 2020 × 640 mm	ideal 4080 × 128 mm

Surfaces: see page 17

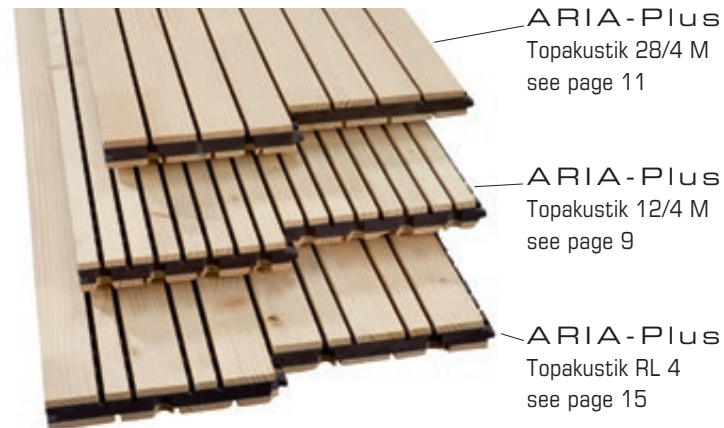

TOP(A)K(U)S(T)I(K)<sup>®</sup> + TOP(P)E(R)F(O)<sup>®</sup>

ARIA-Pure **NEW!**

ARIA-Pure means silver fir through and through! We have the finger-jointed 3-layer silver fir plywood in stock in two 16 mm-thick formats.

Core board size	Topperfo panels	Topakustik planks
4080 × 2050 mm	ideal 2020 × 640 mm max. 4050 × 1216 mm	ideal 4080 × 128 mm
5000 × 2050 mm	ideal 2490 × 640 mm	

ARIA-Pure can also be made of common retail 3-layer plywood boards in spruce or other kinds of wood – simply ask us!

For ceilings, glazed surface treatment provides protection against yellowing; for walls, we recommend an additional coat of water-based paint. Other glazed paint finishes in various colours are also available.

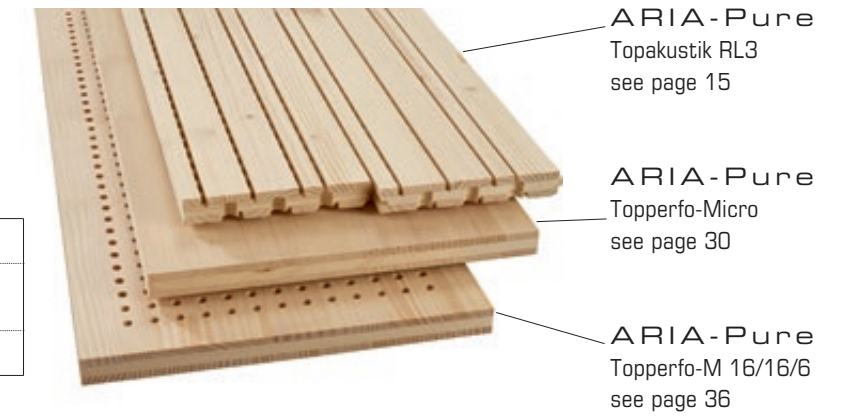

Spruce Hardwood – picture shows 65 × 25 cm



White Fir, finger – jointed-picture shows 65 × 25 cm

13 Living room, Gonten CH – Architect and Photo: Roland Koch Innenarchitektur, Gonten CH 14 Pan Zentrum, Berlin DE – Architect: Parmakerli-Fountis Gesellschaft von Architekten mbH, Kleinmachnow DE – Photo: Allard van der Hoek, Amsterdam NL 15 Gotthard Autobahn Raststätte, Erstfeld CH – Architect: architektur lischer partner ag, Luzern – Photo: Roger Frei, Zürich



13

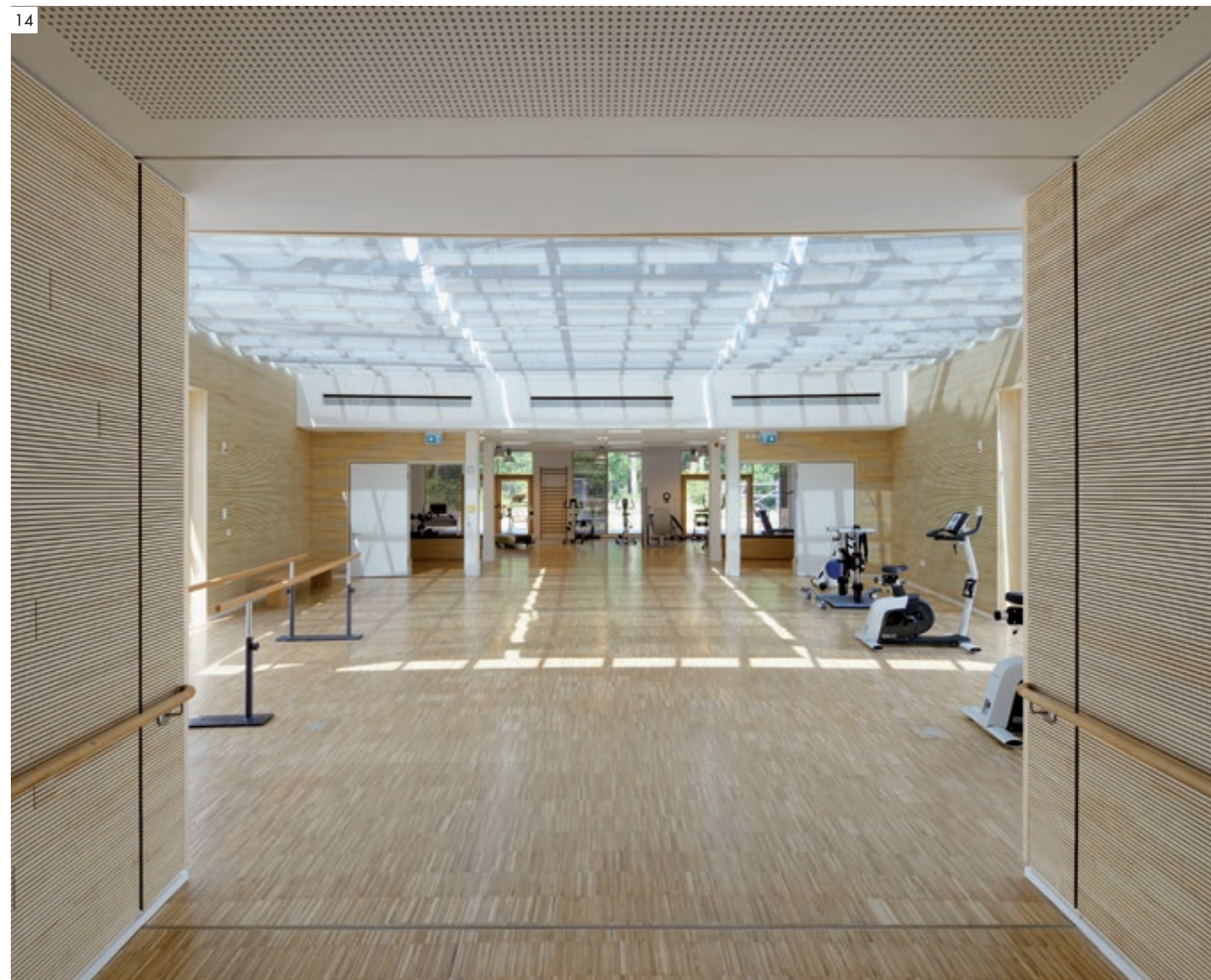

14



15





## MEDIUM DENSITY FIBREBOARD (MDF)

TOPAKUSTIK and TOPPERFO products are manufactured from medium density fibreboard (MDF) as a standard. Thanks to the homogeneous structure, MDF is well suited for this application. MDF panels are produced from soft and hard wood fibers with added binding agents. Only panels meeting the international emission values E1 are processed. Panels are also available in No added Formaldehyde and FSC certified upon request.

### FIRE STABILITY ACCORDING TO EUROCLASS EN 13501-1



TOPAKUSTIK and TOPPERFO have successfully passed extensive tests in accordance with Euroclass EN 13501-1 and are classified as follows in the flame-retardant specification: **B-s2,d0**

Table of Classification			
CH	DIN	EN	US
RF 1	A1	A1-s1,d0	A
RF 1	A2	A2-s1,d0	A
RF 2	B1	B-s2,d0	A
RF 3	B2	D-s2,d0	C

as an indication

US classifications according to ASTM E84 standard

#### This code comprises the following value:

- B little or no contribution to the spread of fire
- s2 little or insignificant smoke emission
- d0 no flammable particles or drops in the event of a fire

#### The system is broken down into the following categories:

- A1 no contribution to the spread of fire
- A2 no significant contribution to the spread of fire
- B little or no contribution to the spread of fire
- C limited contribution to the spread of fire
- D contributor to the spread of fire
- E major contributor to the spread of fire

### EXPANSION AND CONTRACTION OF THE CORE MATERIALS:

Wooden materials are hygroscopic and have a balancing effect on the relative humidity of the room. Changing room humidity also causes the shrinkage and expansion of wooden materials. In air conditioned rooms the panel and plank dimensions can change by +/- 1 mm per 1000mm. In non air conditioned rooms this can increase to +/- 2 mm per 1000mm. Therefore panels and planks should be separated with joints of 3 mm to 6 mm depending on their size.

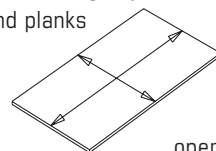

**Acclimatise:**  
The installation should only be done when the normal operating humidity and temperature conditions are in place. The elements are to be acclimatised inside the installation room 3-4 days before installation. Take care elements are exposed evenly to the room air. For more detailed information, please consult the «guidelines for TOPAKUSTIK and TOPPERFO» in the installation manual.

### CONTENT OF UREA-FORMALDEHYDE

We only use class E1 panels or panels glued without any addition of urea formaldehyde whatsoever. An overview of the panels we use is provided here.

Finish	No add. urea formaldehyde	Class E1
Veneered	On request	Products
Colour or white lacquered	Standard products	Special products
Eco (melamine finish)	Standard products	Special products



TOPAKUSTIK, with MDF fibreboard bonded without formaldehyde, has been examined for volatile pollutants as per ISO 1600: it was awarded the best possible classification (A+).



## SPECIAL CORE PANELS

TOPAKUSTIK and TOPPERFO can also be manufactured from other standard core panels. These can be broken down according to requirements with regard to

- Behaviour in fire
- Appearance, e.g. special surface or panel design
- Special properties with regard to stability or moisture

## RESAP®

RESAP is a non-flammable panel (EN A1-s1, d0/DIN A1/CH RF 1) made from natural gypsum and recycled cellulose fibres.

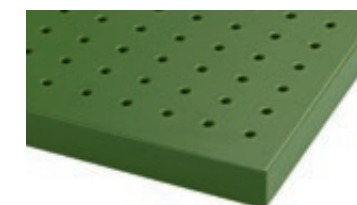

**Painted panels:**  
homogenous design – surface and edges can be finished for seamless transition. The RESAP-Plus version is recommended for a largely non-porous coat of paint.



**Veneered panels:**  
The light-brown/beige colouring of the panel is visible in the grooves or perforations and in combination with oak, beech or light veneers gives a high-quality appearance.

### OVERVIEW OF SPECIAL CORE PANELS

Core Material designation	Fire category DIN (CH)	Suitable for humid rooms				Basic sizes of core materials	Maximum expansion due to humidity increase for 1000 mm length in air conditioning
RESAP®	A1 (RF 1)	-	+	+	-	3080 x 1250	0.4 mm / 1 m = 0.4%
	EN A1-s1, d0						
Cement	A2 (RF 1)	+	-	⊙	-	2600/3100 x 1250	0.8 mm / 1 m = 0.8%
Particle board	B2 (RF 3)	-	⊙	⊙	⊙	DIV	0.8 mm / 1 m = 0.8%
Flakeboard OSB	B2 (RF 3)	~	-	⊙	-	DIV	0.8 mm / 1 m = 0.8%
Forex	B1 (RF 2)	+	-	⊙	-	3050 x 1220	
Plywood	B2 (RF 3)	~	+	⊙	-	DIV	0.8 mm / 1 m = 0.8%
Blockboard	B2 (RF 3)	~	-	~	-	DIV	

**Legend:**  
- unsuited  
+ well suited  
⊙ upon request  
~ conditionally suited, take differences in colour in untreated panels into account  
DIV various further formats, please inquire.

**Explanations:**  
 Wood veneer p. 20  
 Paint p. 21  
 Melamine p. 21

### FOR EXAMPLE: BLACK MDF



Black or coloured MDF core boards offer many interesting possibilities. They contrast well with both painted and wood veneer TOPAKUSTIK planks or panels.

When the core is the finish: All of the core panels are industrially manufactured. Colour differences, even within one production batch, cannot be avoided. The application of a topcoat can make these differences even more apparent.





## WOOD VENEERED SURFACES:

The TOPAKUSTIK products are veneered in all customary types of wood. The veneer are processed individually for each order. This helps to obtain the most even appearance possible for colour and pattern. Furthermore, the veneer appearance is influenced by the cut and the composition of the veneers. Since wood is a natural product, the matching of the veneer must be done in connection with each individual order.



Oak Europe    Knotty Oak    Maple Europe    Maple US    Birch    Ash



am. Nut Tree/Walnut    Cherry US

... and many other types of wood. You can use our configurator to choose your veneer and perforation. The effect can be seen immediately. See [www.topakustik.com](http://www.topakustik.com)



Collection 19-9 ( subject to a nominal charge )  
19 coloured natural wood veneer and 9 Natural wood veneer

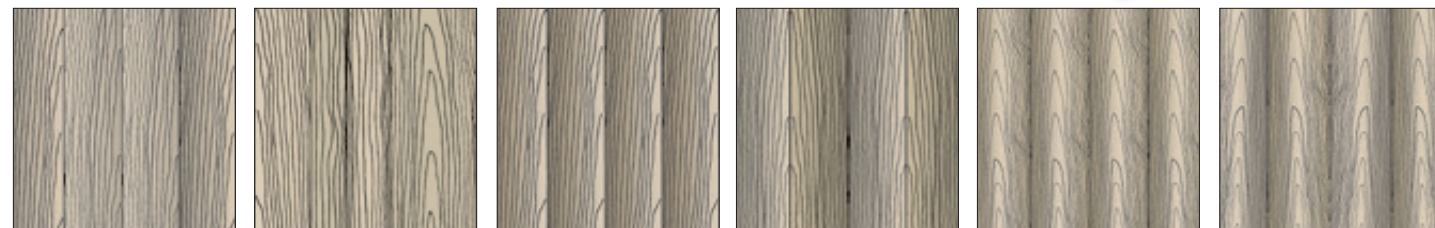

Quarter cut + half crown cut    Random matched    Quarter cut slip matched    Quarter cut book matched    Crown cut slip matched    Crown cut book matched

**Advantage:** uniform impression for whole project

**Disadvantage:** not uniform impression for whole project

### Different lengths of planks and panels:

The choice of the veneers is tailored to the length of the plank or panel. Different veneers may be used for various lengths. If the entire project needs to be manufactured using the same veneer, that needs to be specified as a condition.

### Rift veneers (sliced veneers or true quarters) on panels:

joining rift veneers on the bias is not advisable with certain types of wood such as maple or cherry as the appearance of the veneers becomes striped. We recommend random match veneering = our 'Random matched' range.

## VARNISH:

A high quality, clear, flat varnish is provided on all orders unless otherwise specified. Light kinds of wood such as maple or birch are varnished with a slight lightening effect as a matter of principle.

- NM = natural, gloss varnish
- AM = lightening, gloss varnish



## PAINT SURFACES

Matching is available for any manufacturer's colour specification (RAL/NCS/...). The application is done with the latest generation spray robotics, providing a guaranteed even application. Due to the grooves and perforations of the products, the colour appearance is different from that on smooth surfaces. If TOPAKUSTIK products are finished by the client, please remember that an even paint application, even in the grooves, is absolutely necessary for a good final result.



The advantage of painted surfaces is that the grooves are also the same colour.



White coating in MDF-eco melamine gives the grooves greater prominence.

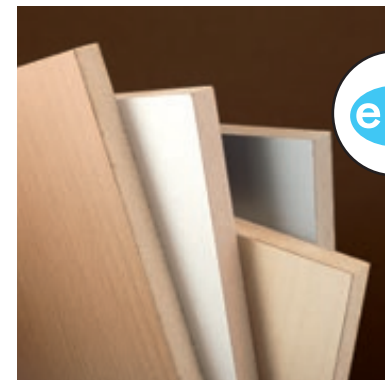

## MELAMINE (eco)

Details for eco:

- 10 different cutting-edge Decors
- All panels are classified as no added urea formaldehyde NAUF
- Short delivery times, all decors in stock NH
- Both fire classes available D-s2,d0 and B-s2,d0 (FR)
- FSC mix possible on request (depending on quantity)

eco basic: 4100 x 2070 mm    5600 x 2070 mm

**NEW!**

eco extra: 4100 x 2070 mm

**NEW!**

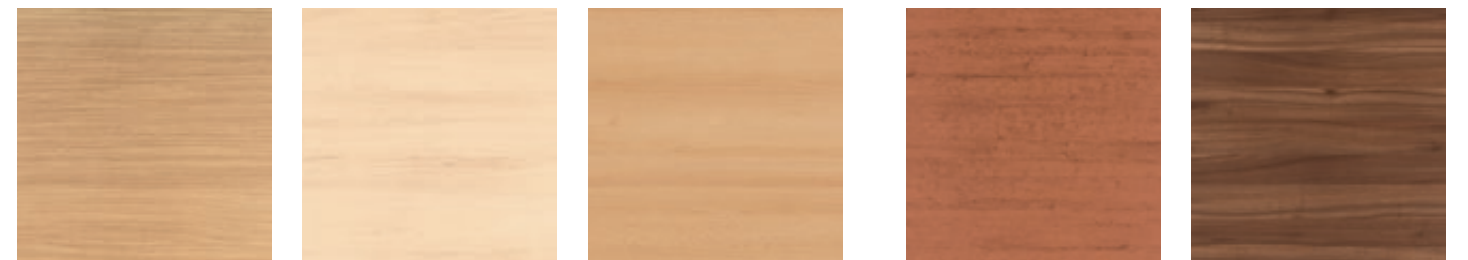

Oak M3280 NTL    Maple M2106 SMA    Beech M112 SMA    Cherry M760 SMA    Walnut M4462 SMA



Ash M3965 NTL    White B3002 LP    Silver L4068 LP    Acacia M4451 NTL    Thermo M6222 NTL



eco eco plus collection: Further melamine finishes for quantities above 150m<sup>2</sup> upon request.

HPL coating: All customary HPL laminate coatings are possible. Contact the factory for details.



## EDGES

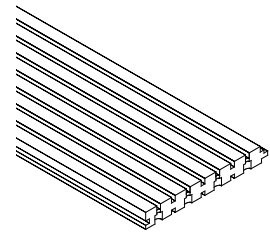

TOPAKUSTIK-planks edge details:

Longitudinal edges with tongue and groove.  
If requested an extra groove can be inserted for fitting with a mounting clip.  
Transverse edges are cut industrially and at a 90 degree angle. When planks of multiple lengths are requested, the perforations are visible on the front edge.

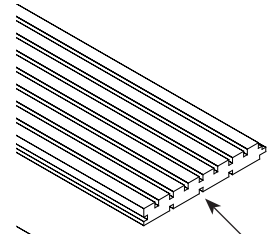

If requested, perforations on the transverse edges are set back. Edge varnished.  
The rear stress relief grooves are necessary for stability and are visible.

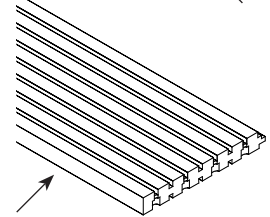

If requested, the first and last plank may have a visible edge without tongue or groove.  
It may also be veneered or painted.

### Product tolerances

**Planks:** the front edges of TOPAKUSTIK planks are supplied with a industrial 90 degree angle cut as a standard. The length tolerance amounts to +/- 3mm. If requested, the planks can be supplied to a «fixed» dimension with a reduced tolerance of approx. +/- 0.25mm per m<sup>1</sup>. This is only recommended for lengths shorter than 2m because of the potential for greater expansion and contraction of core materials.

**Panels:** TOPAKUSTIK panels are produced on computer controlled machinery with tolerances of +/- 0.5 mm per m<sup>1</sup>.

TOPAKUSTIK products are delivered with small tolerances as above. By grooving and perforating, the surface area is increased by a factor of two or three, depending on the design. Therefore TOPAKUSTIK products can react quickly to varying humidity and temperature conditions. Size differences can occur before installation caused by expansion and contraction of core materials during storage and acclimatization.

(> page 18)

TOPAKUSTIK-Panels edge details:

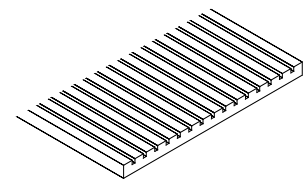

Visible edge, perforation set back  
(Edge finished in coloured paint version!)

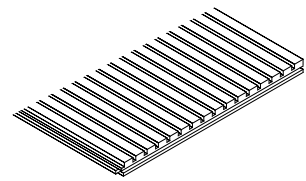

4 mm tongue or groove joint  
– Panel joints need to be shown!

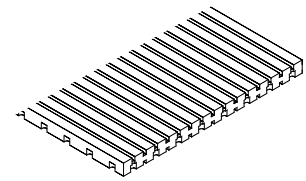

For blind edges, perforations are visible

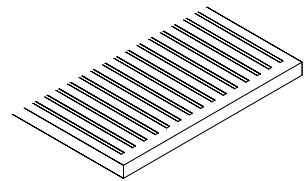

Groove interrupted at edge

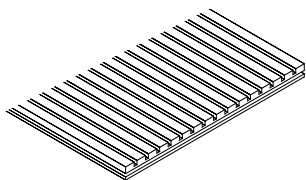

Female rabbet joint 4 mm deep for a spline joint

## CEILING FINISHES FOR PLANKS + PANELS

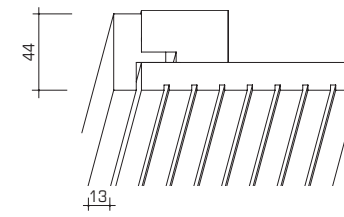

Edge Moulding Type 1

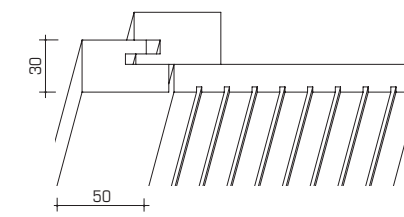

Edge Moulding Type 2

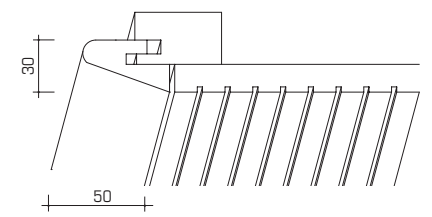

Edge Moulding Type 3

## CEILING FINISHES FOR PANELS

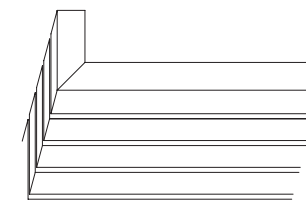

Mitre Type 10

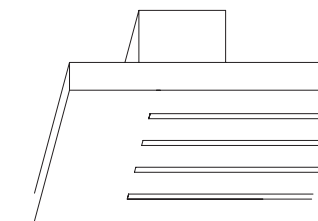

Visible Edge with Grooves set back  
Type 11

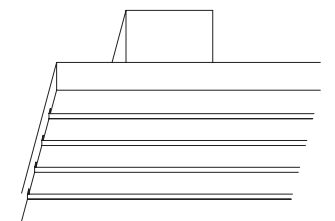

Visible Edge with continuous grooves  
Type 12

## CUTOUTS



On site or factory cut



Produced with interrupted grooves



Inserts for planks  
128 / 256 / 384 mm

## WALL CORNERS AND TERMINATIONS

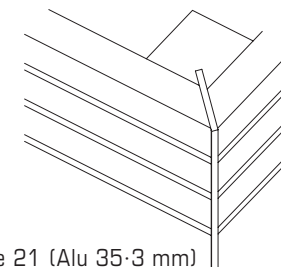

Type 21 (Alu 35-3 mm)

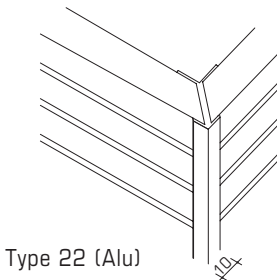

Type 22 (Alu)

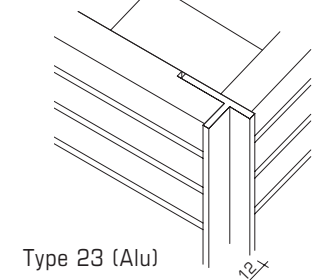

Type 23 (Alu)

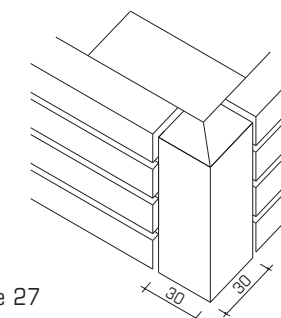

Type 27

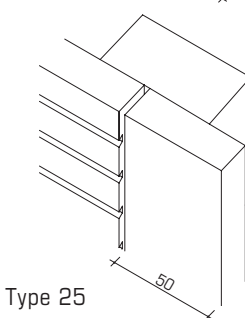

Type 25

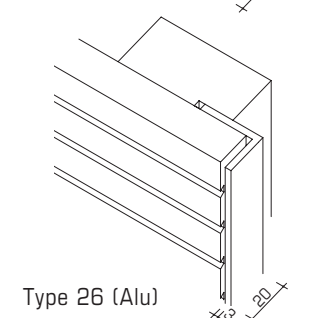

Type 26 (Alu)



## MOUNTING OF TOPAKUSTIK PLANKS

Planks are manufactured with a precise large notch finger joint, which permits a plain ceiling design. However, individual planks or joints may be visible, in particular if dark colours or shiny varnishes are used. The planks are installed without dilation joint, which is only possible because of the narrow plank width of «just» 128mm. However, it is mandatory to observe the installation rules regarding room climate – see page 18!

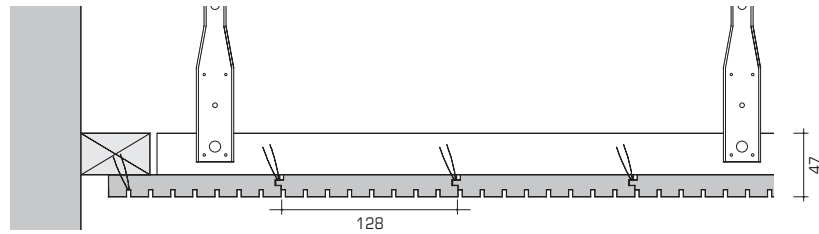

**Mounting on wooden Battens:** The TOPAKUSTIK planks are installed like conventional tongue and groove planks. It is important that compressed air pressure used for the nailing or stapling gun is set precisely, so the staples do not protrude in the groove or penetrate too deeply.

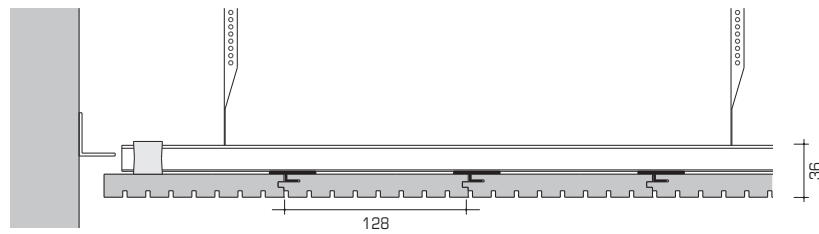

**Mounting on Metal Ceiling Grids:** The TOPAKUSTIK plank is fitted to the suspended H-bar rail with special «twist on» mounting clips. This form of assembly is ideal for non-flammable ceiling finishes.

Narrow grooving (Typ 6/2, 8/3, 9/2) is not suitable for this system

### ACCESS PANEL

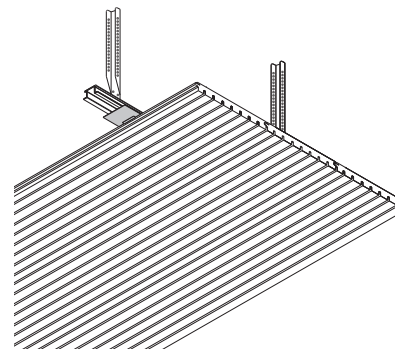
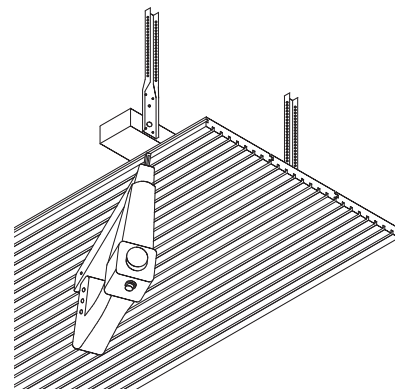
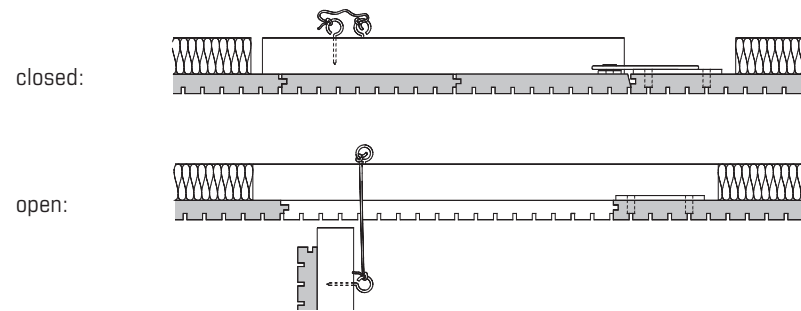

... for more information see installation manual!

### LAYOUT

**Offset joints:** The installation with offset joints permits a slight material expansion without it becoming visible. In combination with joint widths of about 3mm, a clear and tidy joint appearance results.

English

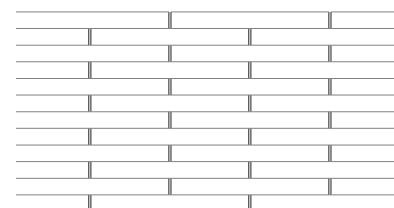

Serrated

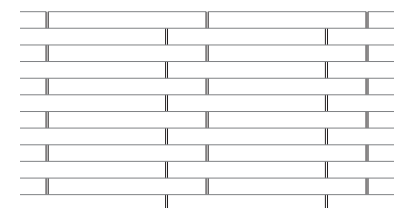

Random

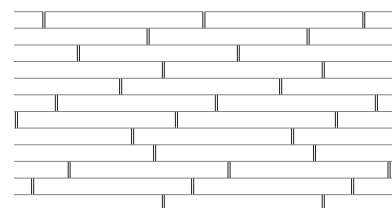

## MOUNTING OF TOPAKUSTIK-PANELS

Joints also have a disassembly function and as a general rule they should have twice the width of the slot on the panel...i.e. 14/2M should be a 4mm joint and 13/3M, a 5mm or 6mm joint. It is extremely important to observe the installation rules regarding room climate – see page 18!

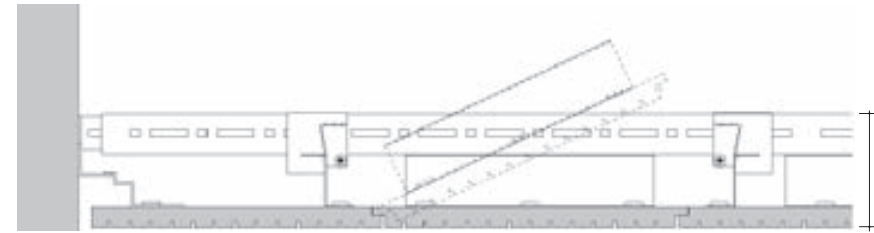

**Z-System:** Every other panel is inserted and can easily be removed by lifting. This system is suitable for all ceilings.  
Panel joints : appr. double width of grooves (2 = 4, 3 = 5, 4 = 6 mm)  
Recommended width of panel 640 mm (axe incl. joints = 642/643/644 mm)

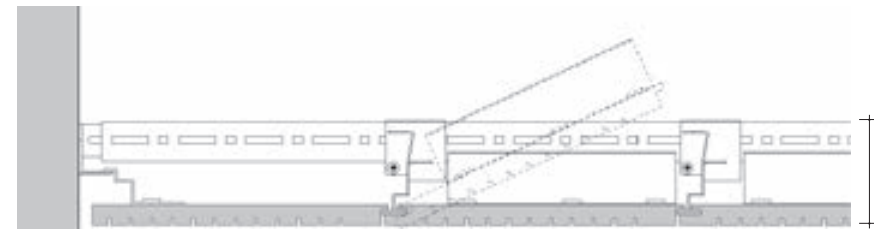
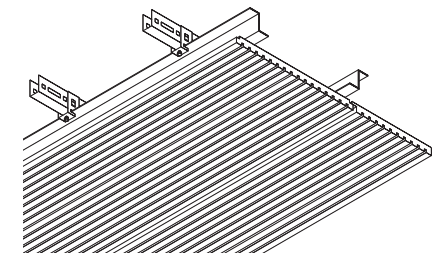

**G-System:** Each panel is easy to remove by lifting.  
Panel joints : appr. double width of grooves (2 = 4, 3 = 5, 4 = 6 mm)  
Recommended width of panel 640 mm (axe incl. joints = 642/643/644 mm)

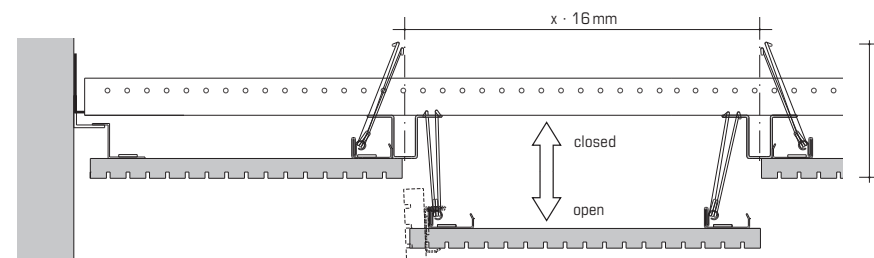
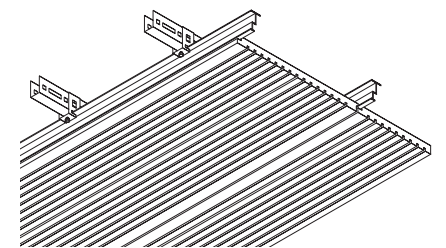

**S11:** Each panel is easy to remove.  
Recommended width of panel 640 mm incl. joint\* (multiple of 16 mm)  
\* Panel joints : appr. double width of grooves (2 = 4, 3 = 5, 4 = 6 mm)  
Max. panel length = 2510 mm

Narrow grooving (Type 6/2, 8/3, 9/2) is not suitable for the system S11

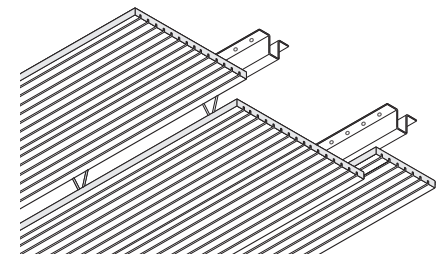

### LAYOUT

**Offset joints:** The installation with offset joints permits a slight material expansion without it becoming visible. In combination with joint widths of about 3mm, a clear and tidy joint appearance results.

English

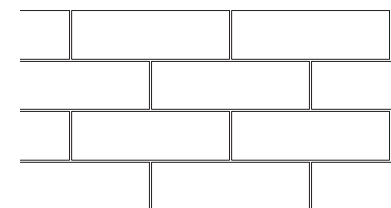

Serrated

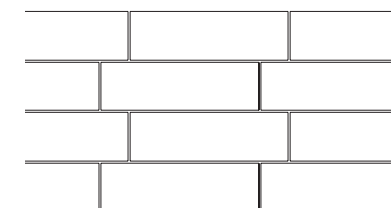

Parallel –  
Not recommended for G-System





## ... SMALLER AND SMALLER!

For a long time, high sound absorption was equated with large open areas that also entailed large perforations. However, architects and designers wanted, and still want, to make the perforations less visible. Following the launch of our TOPPERFO-T and TOPPERFO-Clou products with smaller perforations, we have now achieved hole diameters of a mere 0.5 mm or even 0.3 mm with our TOPPERFO-Micro range. In other words, the circle has been squared: small perforations and high sound absorption combined in one and the same product!



Living room, Küsnacht am Zürichsee CH  
Architect: Sybille Cartier Vogt, Erlenbach – Photo: Sibylle Kathriner Fotografie, Stans  
Product: TOPPERFO-Micro 2/2/0.5, white lacquered

The ceiling cladding in this family home on Lake Zurich exudes cool elegance. The neutral ceiling surface enhances the tasteful decor rather than competing with it. The functioning of the room acoustics is virtually invisible.



# TOP(P)E(R)F(O)®

TOPPERFO are perforated acoustic panels tailor made specifically for each project. Various panel sizes and hole diameters are available for selection. TOPPERFO-Micro and TOPPERFO-Clou, developed by NH, are discrete in their appearance and simultaneously very effective in sound absorption thanks to the small hole diameters. TOPPERFO panels can be provided with various edge designs.

Large perforation diameters may be problematic due to the strong light and dark contrast > risk of flickering!  
 Recommendation: use fine perforations for wall panels (TOPPERFO-T, -Clou or -Micro).

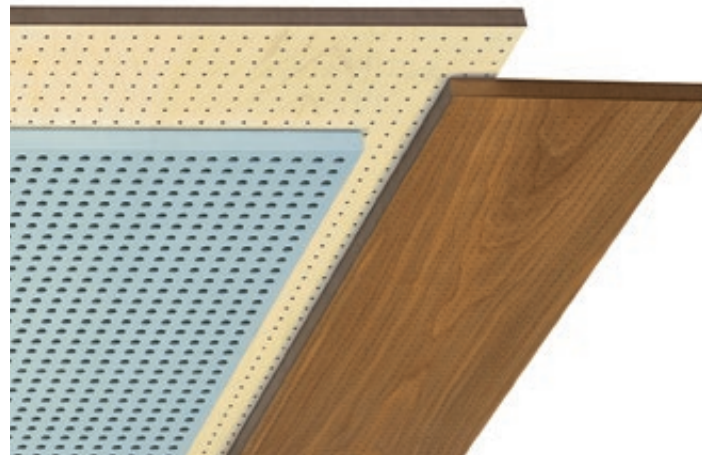

## THE ACOUSTIC SYSTEM

All TOPPERFO types are available with M and T perforations on the rear. This makes it possible for acousticians to match the TOPPERFO surface treatment with the required absorption. The absorption coefficients stated in this brochure were measured according to the ISO 354 standard as described previously. Additional absorption coefficients with other porous materials in the air cavity (e.g. only fleece, melamine resin foam, fiber-glass, etc.) are listed in the TOPAKUSTIK/TOPPERFO sound absorption document.

**Micro Perforation** delivers convincingly high sound absorption – but it can't be seen! The core panel is fully perforated and the covering, veneer or coating material is micro-perforated. TOPPERFO-Micro is suitable for almost all areas, except for outdoor applications.

**Clou Perforation** in core panels with normal flammability. Developed on the basis of T-Perforation, our Clou Perforation product features even smaller bore diameters, starting at 1.2 mm. The sound energy is channelled through four bores on the visible side into one larger bore on the rear side. Materials other than MDF can also be used for core panels.

**Clou Perforation** in low-flammability or non-flammable core panels. The bore on the rear side is replaced by a groove that has a slight influence on the absorption values – note the measurements. The perforation on the visible side remains the same on low-flammability panels; the minimum diameter for non-flammable core panels is 2 mm.

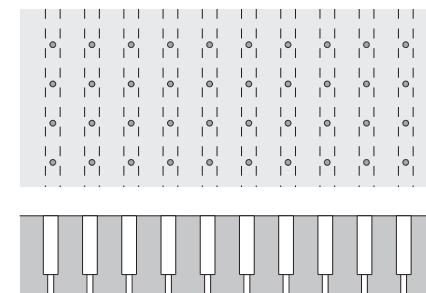
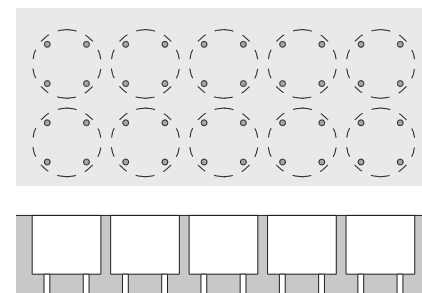
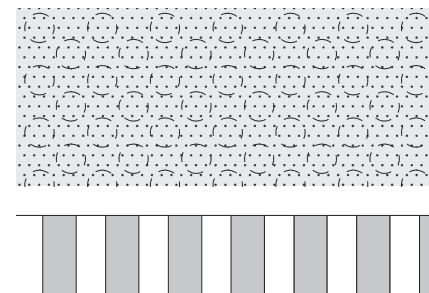

**T-Perforation:** For absorption in the low to medium frequency range. The absorption in the low-frequency range is based on the combination of small diameter holes on the visible side and larger diameter holes on the rear. The small perforations present an aesthetic surface suited for wall finishes.

**M-Perforation:** For absorption in the medium to high frequency range. The absorption depends on the percentage open area, the depth of the rear air cavity between the acoustic elements and the ceiling or wall and the porous absorption in the cavity.

**Reflector:** TOPPERFO products can also be used as reflectors by eliminating the perforations on the rear surface. The absorption figures are then equivalent to those of a standard reflecting panel.

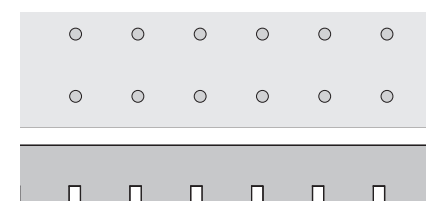
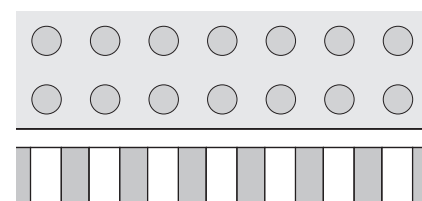
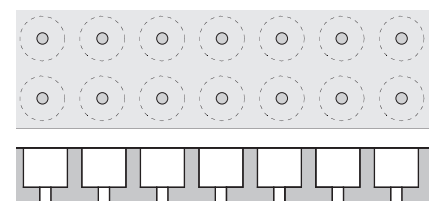

## DIMENSIONS AND MATERIALS



PANELS (Planks see page 42)

Core panel	not fire rated D-s2,d0 (DIN B2)			fire retardant B-s2,d0 (DIN B1)			non-flammable		
	Surface/ Thickness	Paint 16 mm	Wood Veneer 17 mm	Melamine 16 mm	Paint 16 mm	Wood Veneer 17 mm	Melamine 16 mm	Paint 16 mm	Wood Veneer 17 mm
Panels	max. in mm	3648 x 1216	3648 x 1216	3648 x 1216	3648 x 1216	3648 x 1216	3648 x 1216	3080 x 1216	3080 x 1216
	ideal: in mm	2032 x 992	2032 x 992	2032 x 992/640	2032 x 992/640	2032 x 992/640	2032 x 992/640	1540 x 608	1540 x 608
		2780 x 992	2780 x 992	2780 x 992/640	2780 x 992/640	2780 x 992/640	2780 x 992/640	2540 x 608	2540 x 608
		3648 x 640	3648 x 640			3640 x 640		3080 x 608	3080 x 608

ideal means optimal use of MDF core – custom lengths are also available  
 Date 2019 – please check the current dimensions on [www.topakustik.com](http://www.topakustik.com)

Fire category – more information page 18/19

eco page 20/21

## EDGES

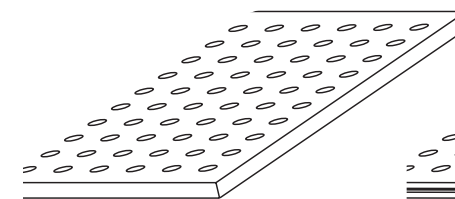

Clean cut

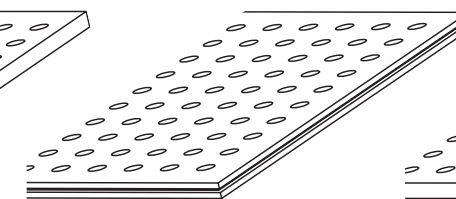

With surrounding groove and tongue

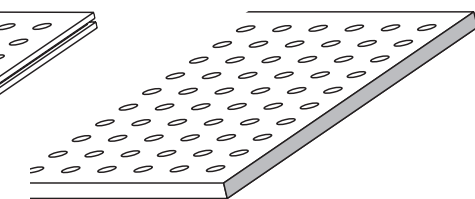

Visible edge

... or according to your specifications

## MOUNTING

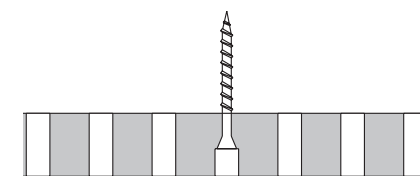

TOPPERFO-M, Ø 6 mm  
 Special screws: in half depth «dummy» perforations

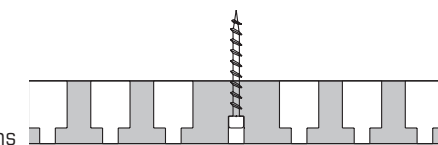

TOPPERFO-T, Ø 4 + 5 mm  
 Special screws: in half depth «dummy» perforations

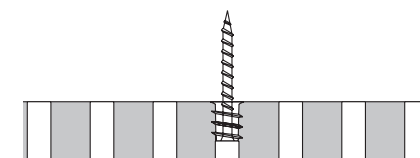

TOPPERFO-M, Ø 8 mm  
 With insert from rear side



See installation manual!



# TOP)P)E)R)F)O)®-Micro

With TOPPERFO-Micro, the sound absorption function becomes almost completely invisible. The perforation measures a mere 0.5 mm (or even 0.3 mm), so it is virtually invisible from a certain distance. TOPPERFO micro-perforation is available in various grids and diameters, depending on the required level of sound absorption. The choice of surface coverings is also virtually unrestricted. All veneers and paint colours are available, as well as CPL and HPL surfaces by arrangement.

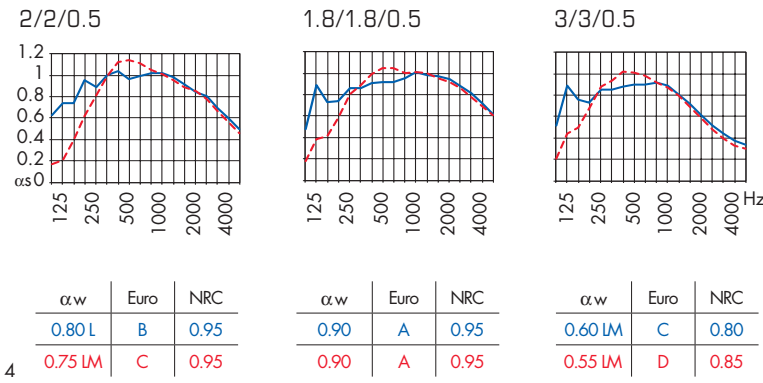

The micro-perforation is provided in fields with a width of around 150 mm. In sided light, it is possible that the excess length between the individual fields becomes visible on UniEco decors or if a dark colour varnish is used. The grid 1.8/1.8 is therefore not recommended for these surfaces. For a grid of 2/2, we recommend to provide samples.

**NEW!**  
**MICRO-DIRECT**

Micro-perforation for almost all boards! We transform industrially manufactured boards "directly" into a sound absorber! For example:

- Melamine-coated boards – see our Eco collection, page 21
- Branchless three-layer or solid boards – see support plate, page 17
- MDF boards veneered by a joinery (> 800 x 300 mm)
- painted MDF boards with colour... and many more

**MICRO-GRAPHIC**

Graphic designs and patterns are available in every imaginable form. Would you like a portrait, or do you prefer an abstract pattern? The possibilities are virtually limitless. The back cover of this brochure shows a project featuring an abstract pattern.

16 Galerie Lafayette, Paris FR – Architect/Photo: CALQ Architecture, Paris FR 17 Kantonsspital, Luzern CH – Architect: Schärli Architekten, Luzern CH – Photo: Kantonsspital, Luzern CH

18 Ericusspitze, Hamburg DE – Architect: Henning Larsen Architects, Kopenhagen DK – Photo: Anke Müllerklein, Hamburg DE

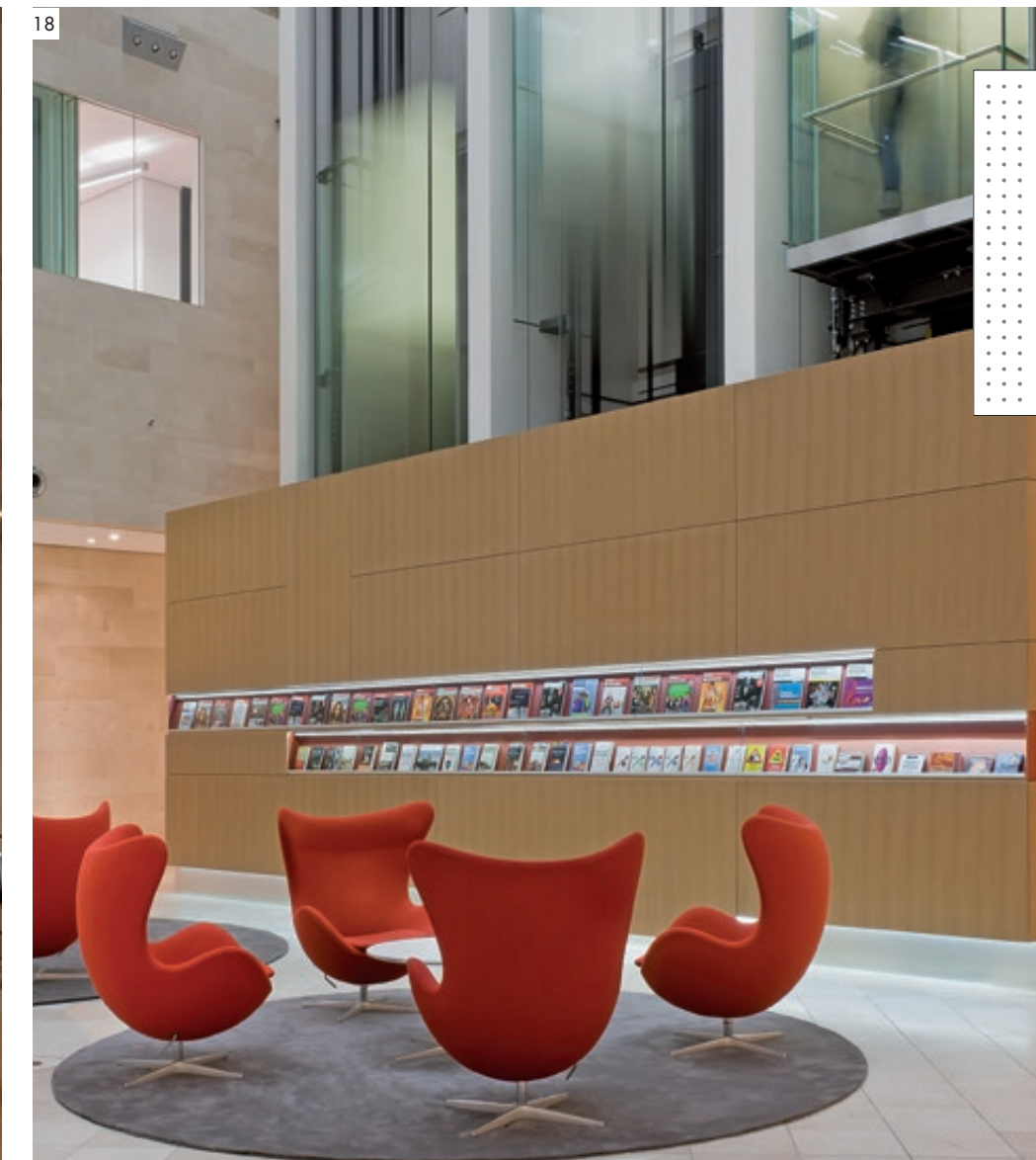



# TOP)P)E)R)F)O)®-Clou

The fine Clou perforation in an 8mm grid with a diameter of only 1.2mm can hardly be seen at a distance. The wooden texture is therefore completely retained in its natural beauty.

	rear	8/8	6,4/6,4	5,3/5,3
MDF not fire rated	perforated	Ø 1.2mm	Ø 2.0mm	
MDF fire retardant	grooved		Ø 2.0mm	
Resap				

Clou perforation is provided over the whole surface to add the benefit of a shine. The middle of the last perforation row should therefore be at the following distance from the board edge:

- Grid 8/8            x = max. 6,5mm
- Grid 6,4/6,4        x = max. 5,0mm
- Grid 5,3/5,3        x = max. 4,0mm

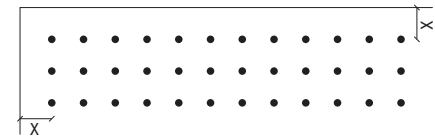

TOTAL THICKNESS  
 ——— ≈ 226 mm  
 - - - - - ≈ 66 mm  
 More information Page 4

## 8/8/1.2

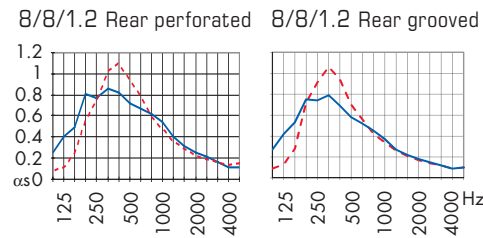
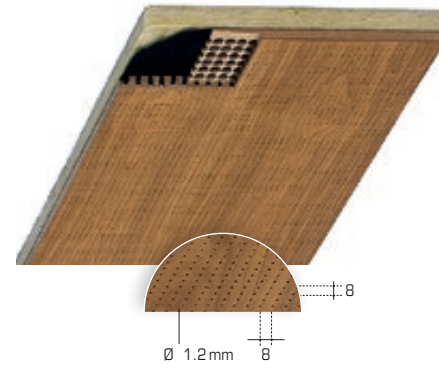

αw	Euro	NRC	αw	Euro	NRC
0.30 LM	D	0.55	0.25 LM	E	0.45
0.30 LM	D	0.60	0.25 LM	E	0.50

## 8/8/2

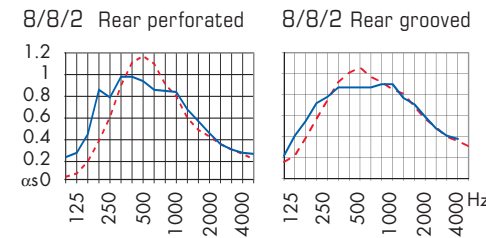
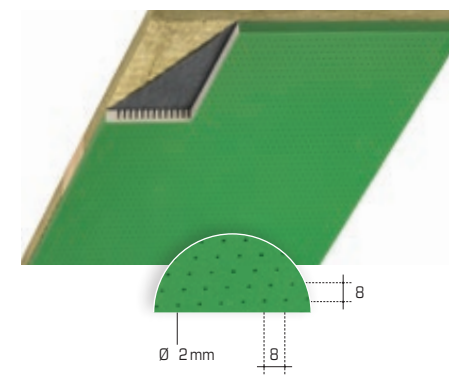

αw	Euro	NRC	αw	Euro	NRC
0.45 LM	D	0.75	0.45 LM	D	0.80
0.45 LM	D	0.75	0.55 LM	D	0.80

19 Alfa Laval, Denmark DK – Architect: PLH Arkitekter, Copenhagen DK – Photo: Fotograferne, Nibe DK 20 APA Tower, USA – Architect: Gensler, USA – Photo: Keith Trotta, USA

21 Centre scolaire, Salvan CH – Architects: Bonnard & Woelfray, Monthey CH – Photo: Patrick Zufferey, Sierre CH



## DIGITAL PRINT



TOPPERFO-Clou and -Micro is also ideal for printed walls or ceilings. Because the Clou- or Micro-perforation is almost invisible, it does not clash with the printed subject – but the surface still absorbs sound. At the DaVinci College high school in Roosendaal (Netherlands), the pupils' imaginative versions of the Mona Lisa were assembled to create a very unusual collage.

Photo: Petra Appelhof, Nijmegen NL



TOP)P)E)R)F)O)® - T

The T-perforation developed and successfully used by NH Akustik+ Design AG has a discreet effect, yet offers appreciable absorption.

TOPPERFO-T panels are available with perforation bores of Ø 3, 4 and 5 mm. Decreasing the diameter of the visible perforations, shifts the absorption maximum to a lower frequency.

See page 29 for dimensions and materials  
See page 20/21 for surfaces

16/16/10-5

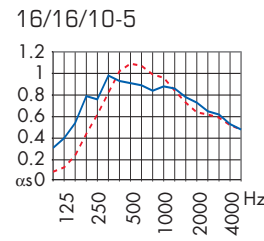
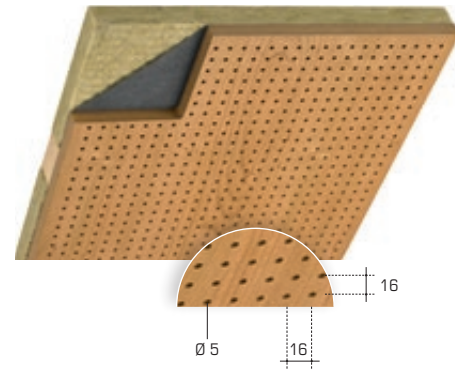

α <sub>w</sub>	Euro	NRC
0.70 L	C	0.80
0.70 M	C	0.80

TOTAL THICKNESS  
— ≈ 215 mm  
- - - ≈ 55 mm  
More information Page 4

16/16/10-4

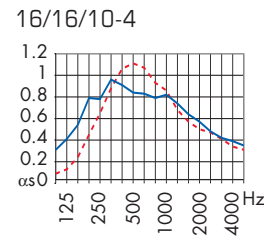
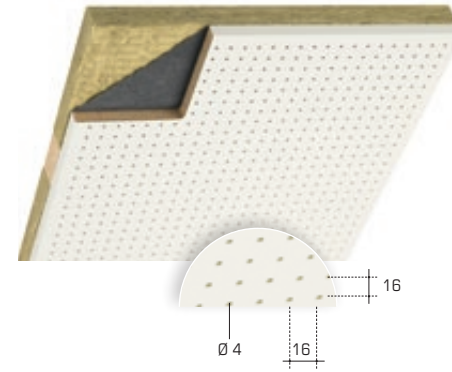

α <sub>w</sub>	Euro	NRC
0.55 LM	D	0.75
0.50 LM	D	0.80

16/16/10-3

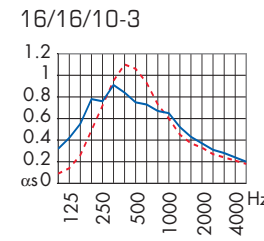
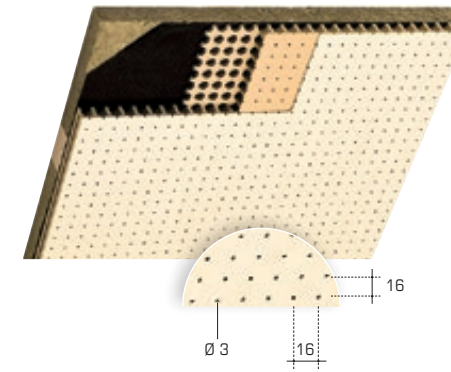

α <sub>w</sub>	Euro	NRC
0.40 LM	D	0.65
0.35 LM	D	0.70

22 Swiss Lounge, Flughafen Zürich CH – Architect: Greutmann Bolzer AG für Gestaltung, ZH CH – Photo: Valentin Jeck, Stäfa CH 23 LVM, Münster DE – Architect: HPP Architekten, Düsseldorf, DE – Photo: HGEsch/Hennef, Blankenberg DE 24 Family Lodge + Spa, Smoker Lounge, Melchsee-Fruitt CH – Architect: Architekturwerk AG, Sarnen CH – Photo: Kathriner Fotografie, Stans CH





TOP)P)E)R)F)O)® - M

TOPPERFO-M are acoustic panels in their conventional form in all materials and surfaces. Perforation-free edges and un-perforated borders for cut-outs are available as a client's choice. Other hole spacings and bore diameters are available upon request.

See page 29 for dimensions and materials  
See page 20/21 for surfaces

Hole spacings and bore diameters

Offset 16/20/40				
x	y	Ø	open area	ISO 354
16	16	6	12%	✓
16	16	8	19%	✓
16	16	10	31%	✓
40	40	10	5%	✓
20	20	10	20%	✓
20	20	8	12%	✓
20	20	6	7%	✓

... and many others!

16/16/6

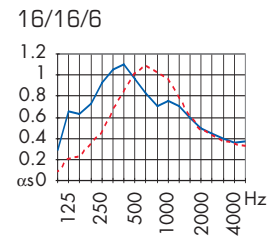
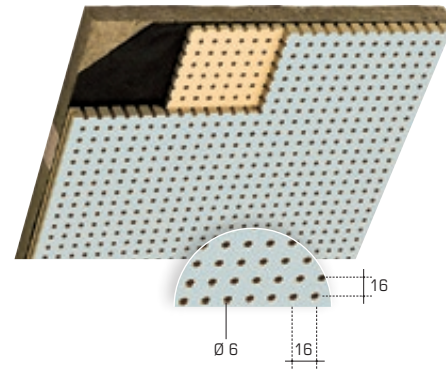

α <sub>w</sub>	Euro	NRC
0.50 LM	D	0.80
0.50 M	D	0.75

16/16/8 (10)

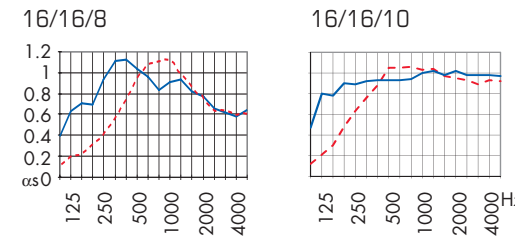
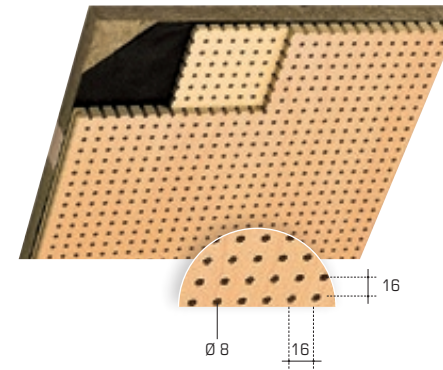

α <sub>w</sub>	Euro	NRC
0.75 LM	C	0.90
0.70 M	C	0.80

20/20/8 (6)

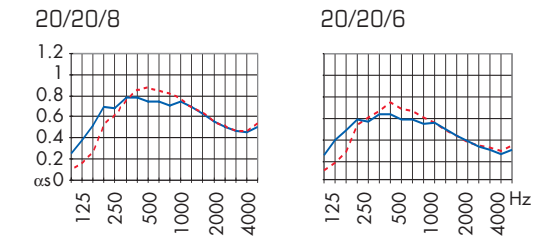
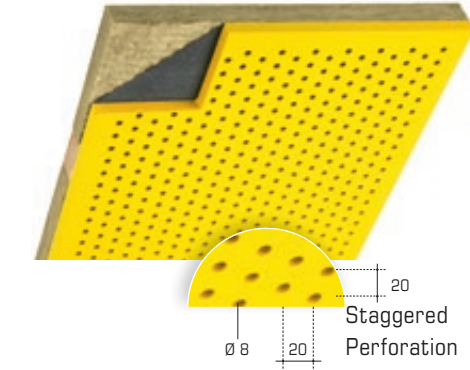

α <sub>w</sub>	Euro	NRC
0.60 L	C	0.70
0.60 LM	C	0.70

TOTAL THICKNESS  
— ≈215 mm  
- - - ≈55 mm  
More information Page 4

25 Ernst & Young, London GB – Architect: Perkins + Will, London GB – Photo: David Churchill, Hove GB 26 Campus Trivaux Garenne, Clamart FR – Architecte: Le Penhuel Geatan, Paris FR –

Photo: Sergio Grazia, Paris FR 27 Sporthalle, Niederglatt CH – Architect: L3P Architekten, Regensberg CH – Photo: Vito Stallone, Dottikon CH

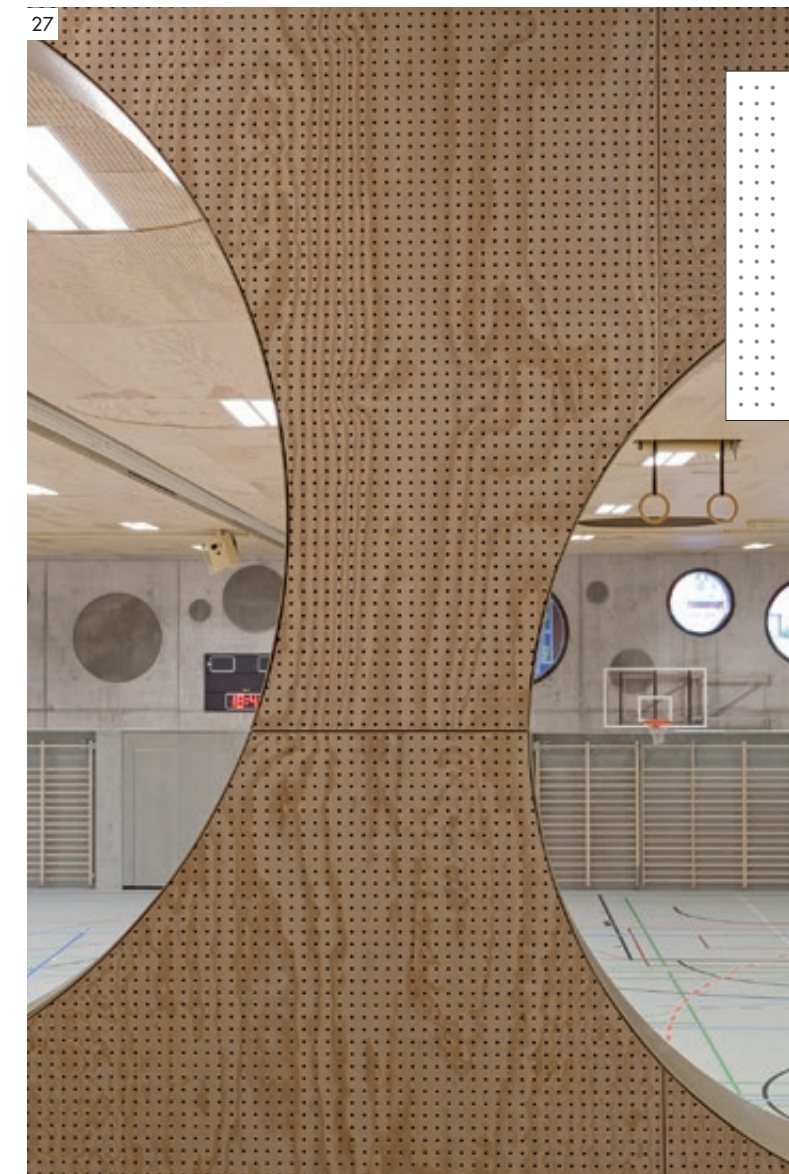



# TOP)P)E)R)F)O)® -Bubble TOP)P)E)R)F)O)® -Split

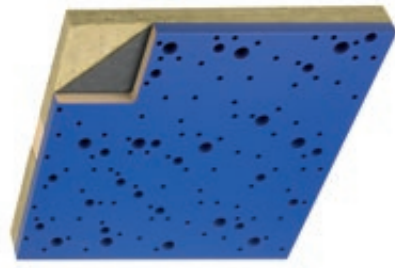

Three different holes



Longitudinal slots

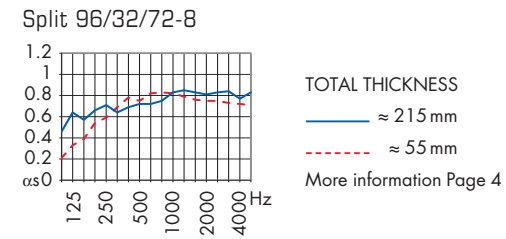
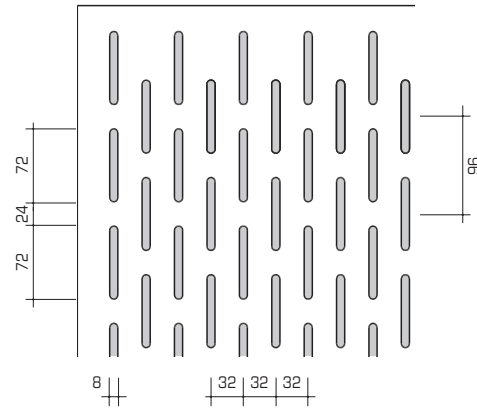
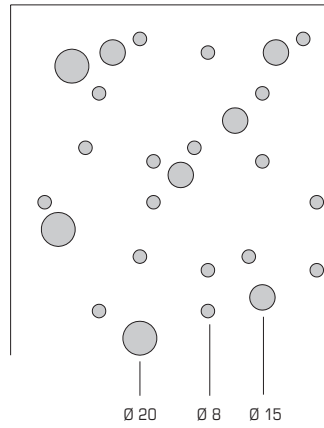

# TOP)P)E)R)F)O)® -Graphic



Star 8



Text 8 (or 6)



Rain 8



Rollo

Photos: Factory NH Akustik+ Design AG

## UNO GRAPHIC

Individual perforations are exposed to create a graphic pattern. This page shows just a few ideas, but the possibilities are almost unlimited. The only rule: the bore grid of 16 mm must always be observed. Sound absorption values are available for «minus 20%» and «minus 40%» of the perforation.

16/16/8-19%

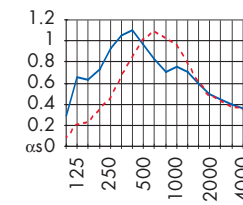

16/16/8-15% «minus 20%»

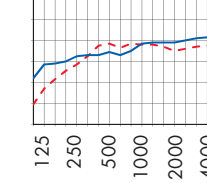

16/16/8-11% «minus 40%»

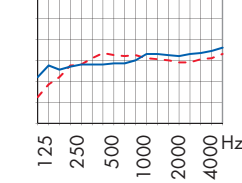

## GRAPHIC MULTI

Multiple bore diameters offer considerably more possibilities, but production is also more complex.

Many other designs under [www.topakustik.ch/products/topperfo/graphic](http://www.topakustik.ch/products/topperfo/graphic)

28 Kantonbank Graubünden, Chur CH – Architect: Domenig Architekten, Chur CH – Photo: Feiner Ralph, Chur CH 29 Devon Energy, USA – Architect: Kendall Heaton Architects, Houston

USA 30 Affenhaus, Zoo Basel CH – Architect: Peter Stiner, Basel CH – Photo: Zoo Basel CH



28



29

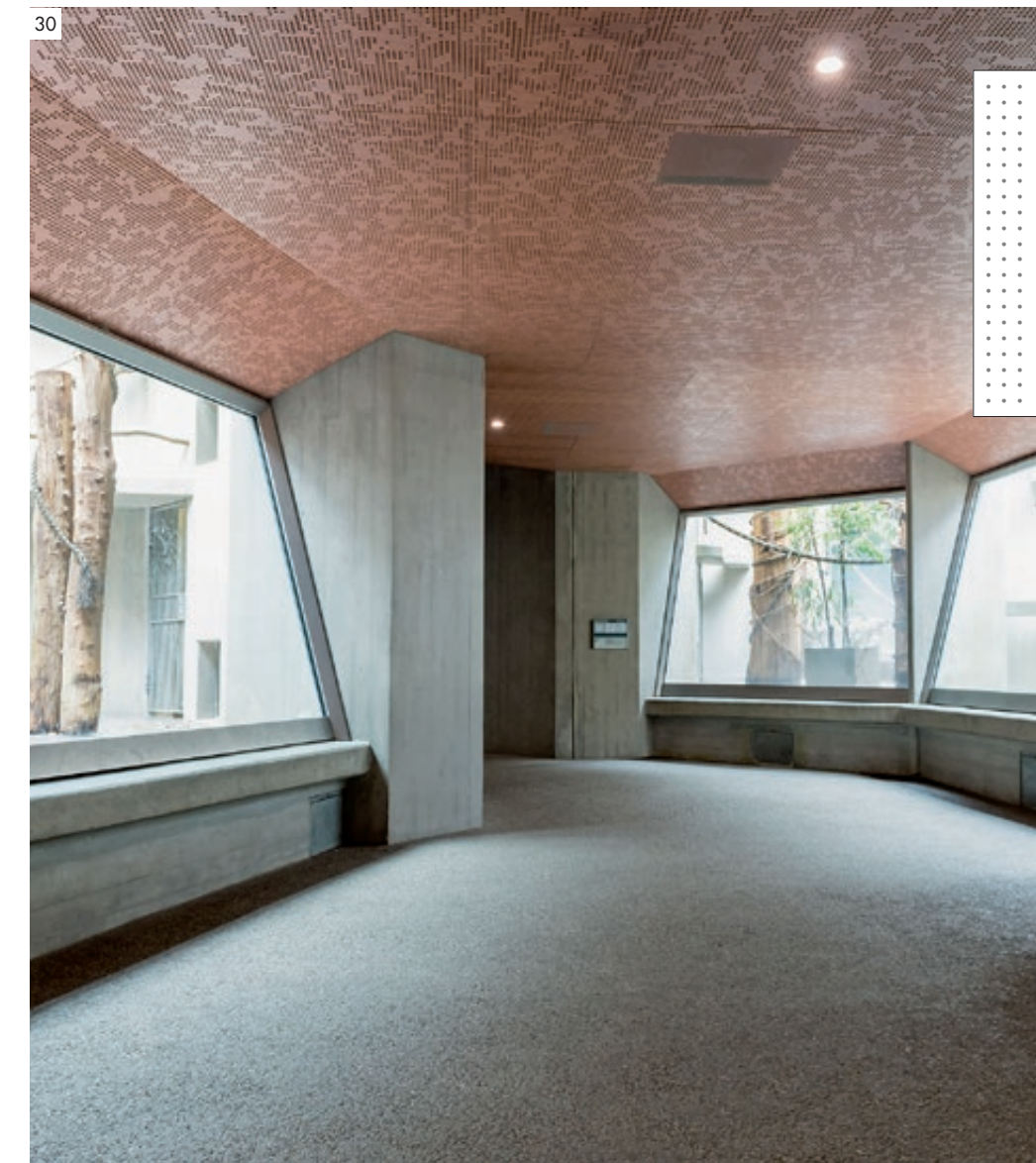

30



## COLLABORATION

We offer far more than innovative products that bring together architectural materials with acoustical performance. Our strength in systems engineering coupled with the excellent craftsmanship of our fabricators allows us to also bridge invention and reality. We offer time tested engineering and installation strategies for the most unique projects. Early design motifs can be quickly adapted into prototyping for feasibility studies, and our design commitment maintains its endurance through the entire project lifecycle to final commissioning. Our goal is to both encourage creativity and meet its demands.



*Falkonergårdens Gymnasium DK  
Architect: Falko Arkitekter, Copenhagen – Photo: Stammers Kontor, Copenhagen  
Product: TOPPERFO-M 16/16/8, Oak veneered*

The extension built onto the Falkonergården high school in Frederiksberg, Denmark, houses a rather unusual gymnasium. The Falko Arkitekter firm created an additional space between two traditional brick buildings, providing accommodation for sports as well as meetings. TOPPERFO panels with a large M-perforation alternating with smooth veneered areas were used for the wall claddings. The installation was slightly curved.



# TOPPERFO®-Planks **NEW!**

TOPPERFO planks allow a line effect combined with circular perforation. The length can be chosen as required. All surfaces and fire categories are possible.

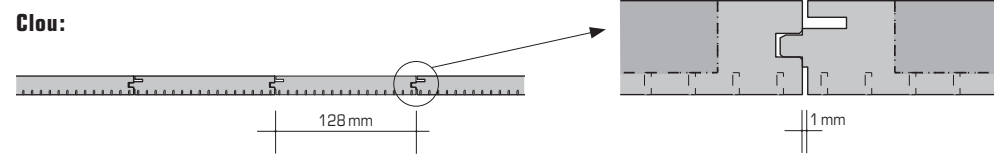
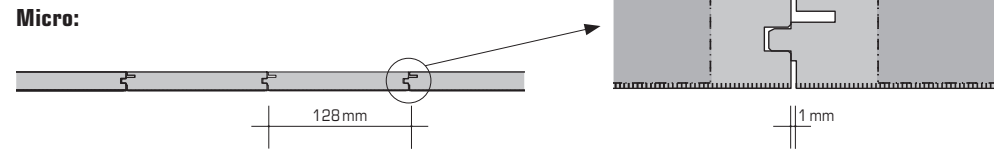

other types of perforations or different widths on request

31 4 Times Square Durst building, New York, USA – Architect: Studios Architecture, New York – Photo: @jeremyfrehette



31

# SIXTY-SYSTEM

(US = 2x2 GRID PANELS)

The ceiling system offering maximum choice and extremely easy assembly. Sixty-System 2x2 grid panels fit into all standard T-profiles.

with H-profiles:

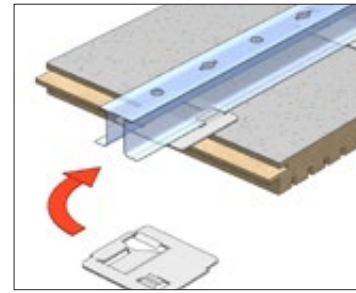

with T-profiles:

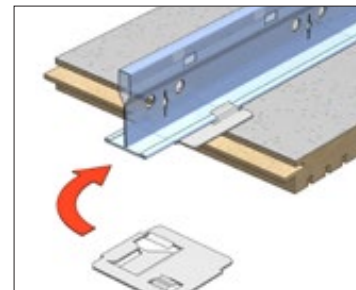

...or with screw clip

Ungrooved borders  
Grooving without border

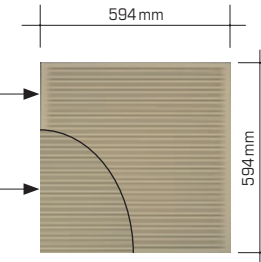

Ungrooved borders  
Grooving without border

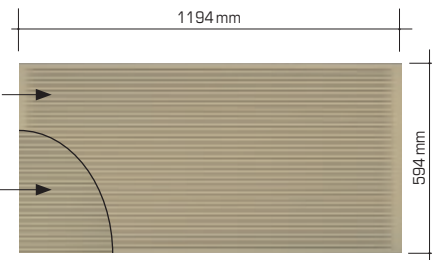

Opening upwards: types A, B and C

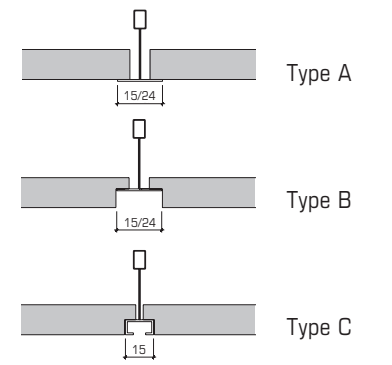

Opening downwards: type D

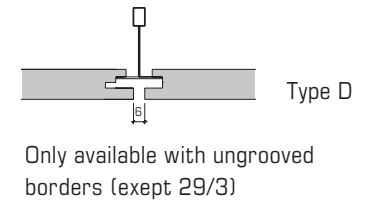

32 Restaurant Compas, Vernier CH 33 TOPAKUSTIK Sixty Typ 29/3 M 34 TOPPERFO Sixty Typ M, 16/16/6



32

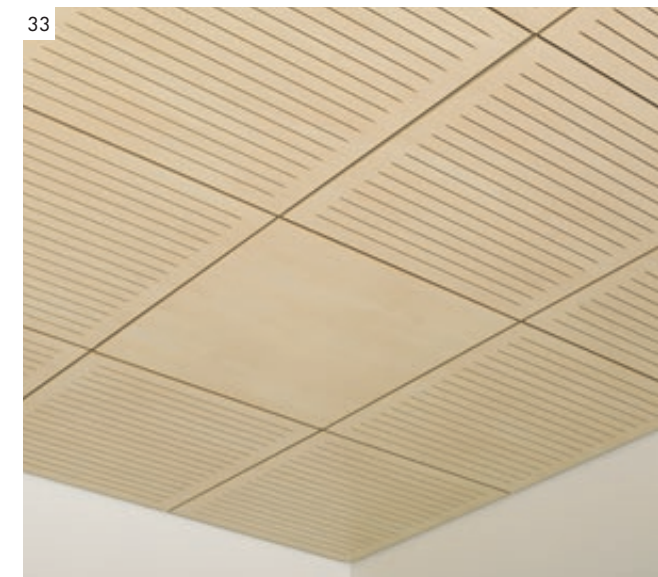

33

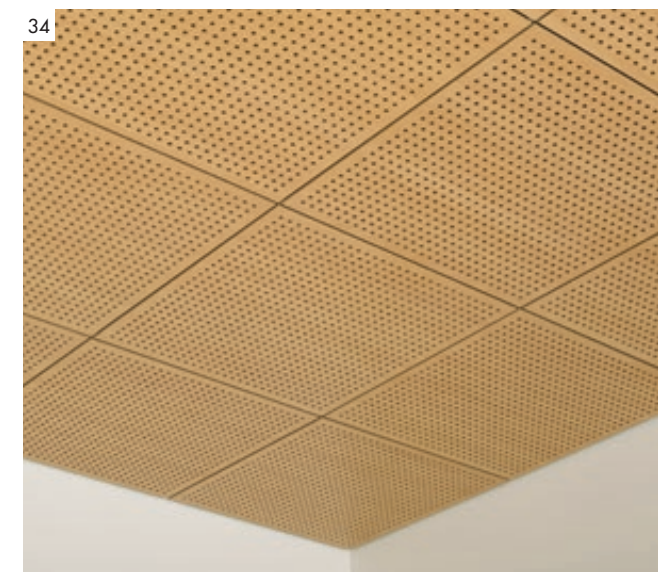

34



# CABINET FRONTS

Cabinet fronts or rear walls of cabinets can be used as sound absorbers. The following products are most suitable: TOPAKUSTIK 14/2, 19/2, 6/2, TOPPERFO-Micro/-T and Clou.

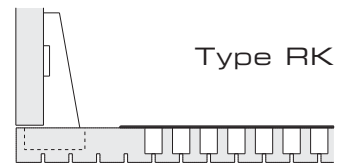

Type RK

In conjunction with the fleece attached to the inside (RK 280), the acoustic surface ensures an absorption across the entire frequency band. The fleece developed by NH is tear-proof and set back from the hinges and handles.

→ 3 point-lock must be used!

Topakustik:

Type	$\alpha_w$	Euro	NRC
RK 9/2 M	0.55	D	0.56
RK 14/2 M	0.60 (H)	C	0.68

Topperfo:

Type	$\alpha_w$	Euro	NRC
RK Clou 8/8/1.2	0.35 (LM)	D	0.54
RK Micro 2/2/0.5	0.7	C	0.82



Door RK inside

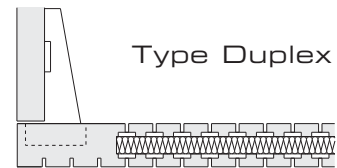

Type Duplex

Duplex is particularly suited to large hinged or sliding doors. These have invisible, integrated absorptive panels.

→ 3 point-lock must be used!

Topakustik:

Type	$\alpha_w$	Euro	NRC
sw* 14/2 M	0.50	D	0.55

sw\* is comparable to Duplex

Topperfo:

Type	$\alpha_w$	Euro	NRC
sw* 16/16/12-3	0.25 (L)	E	0.27
sw* Clou 8/8/1.2	0.35 (L)	D	0.39

# FORMED SHAPES

For ceiling clouds, curved walls and other shapes TOPAKUSTIK and TOPPERFO elements can be used for shaped wall and ceiling finishes without significant additional effort. For radii above 10 metres, the standard TOPAKUSTIK planks are assembled on the round sub-construction in a segmented way. For smaller radii, the planks or panels can be made flexible by deeper relief grooving on the rear side. In this way, the panels can simply be adapted to the curved sub-construction.

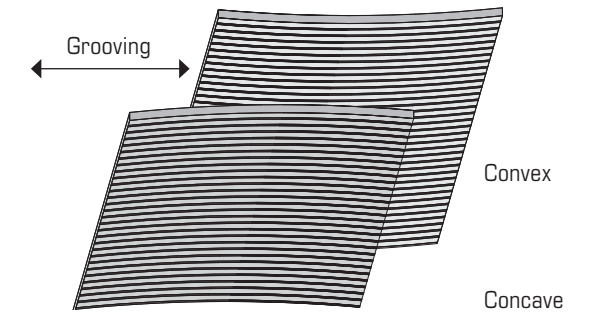
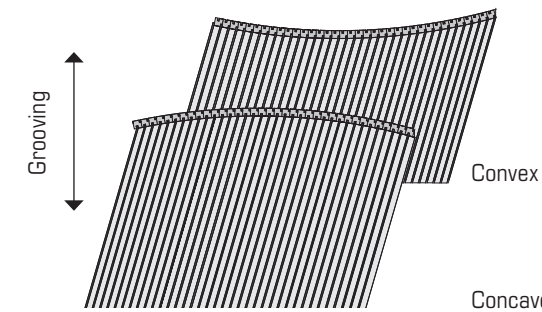

	Radius	Machining
Planks	> 10 m > 5 m	Assembled in segments Grooved on the back
Panels	> 5 m > 1 m	Grooved on the back Prepared as shapes in the factory

	Radius	Machining
Planks	> 15 m > 8 m	No special machining Grooved on the back
Panels	> 8 m > 1 m	Grooved on the back Prepared as shapes in the factory

35 Centre scolaire, Fully CH – Architect: Suter Sauthier Architectes SA, Sion CH – Photo: Patrick Zufferey, Sierre CH 36 Binagadi Auditorium, AZE – Architect: Lider Monolit, Baku AZE – Photo:

Idris Ahadov, Baku AZE 37 EKZ, Dietikon CH





## GYMNASIA

Wall and ceiling finishes are subjected to high impacts in gymnasias. TOPAKUSTIK and TOPPERFO finishes, in combination with the subconstruction systems specifically developed for sports venues, fulfil the high requirements with regard to physical impact and room acoustics. Various TOPAKUSTIK and TOPPERFO products have been tested and certified to DIN 18 032 part 3.

L 4266-III/IV	13/3M, 12%	Planks MDF 19 mm
L 4266-IV/IV	28/4M, 7.5%	Planks MDF 19 mm
L 4266-I/IV	16/16/8	Panels MDF 19 mm
L 4266-II/IV	16/16/10-5	Panels MDF 19 mm
L 4266-I/II	16/16/8	Impact wall test
L 4266-II/II	28/4M	Impact wall test

## SWIMMING POOLS

For acoustic finishes in high humidity rooms, requirements corresponding to the application are to be fulfilled, e.g.:

- Ceilings and walls constructed to local code requirements
- Rear ventilation of wall and ceiling finish
- Use of corrosion-proof subconstruction materials
- Use of specific, moisture-resistant core panels in production
- Use of specific varnishes or impregnations
- Consideration of the (extraordinary) shrinkage and swelling properties of the core panels
- Water-repellent absorbers such as polyester fleece

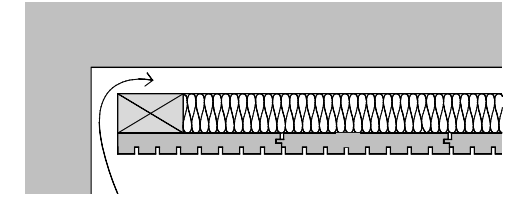

The use of acoustic surfaces in damp areas is highly complex. Please contact us with your project and we shall be happy to assist you with developing it.

38 Centre scolaire, Salvan CH – Architect: Bonnard Wœffray Architectes, Monthey CH – Photo: Patrick Zufferey, Sierre CH



39 École de Châteauneuf, Conthey CH – Architect: Bonnard Wœffray Architectes, Monthey CH – Photo: Patrick Zufferey, Sierre CH



40 Infinity House, GB – Architect: Spaced Out Ltd., London GB – Photo: Josh Pulman, London GB





# QUALITY IS NEVER A COINCIDENCE

What we do, we do perfectly: to the highest quality for our customers, with respect for the environment, with products that comply with EN standards and with world-wide patent protection for our inventions.

TOP(A)K(U)S(T)I(K)<sup>®</sup>

TOP(P)E(R)F(O)<sup>®</sup>

RESA'P<sup>®</sup>

are registered brands of NH Akustik + Design AG



CH-PATENT  
No 683 112



EN 13501-1  
FIRE CLASSIFICATION



FSC products  
are marked

USA-PATENT  
No 5, 362, 931  
No 5, 422, 446



EN 13986  
WOOD-BASED PANELS

EN 20354  
SOUND ABSORPTION

- 41 KKL, Luzern CH Architect: Jean Nouvel, Paris FR
- 42 Reichstag Berlin DE Architect: Foster + Partner, London GB
- 43 New York Times, New York USA Architect: Renzo Piano, Genova/Paris
- 44 Burj Khalifa 828 m, UAE Architect: Adrian Smith SOM, Chicago USA

Rear cover photo: Micro Graphic



# TOPAKUSTIK-SERVICE

### Basic sample box

Contains 4 samples

### Eco sample box

### ARIA-Plus sample box

### Deluxe sample box

(subject to a nominal charge)

17 different samples including 5 different veneers

**TOPAKUSTIK installation manual** with sub-constructions, guidelines and tips for the tried and tested TOPAKUSTIK installation systems. For specific installation solutions, please contact our technical department.



### A5 sample from stock:

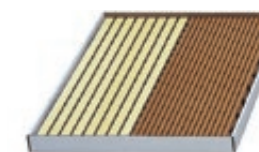

		eco										eco									
		white RAL 9010	Beech steamed	Maple european	Birch	Oak european	Am. Walnut	Am. Cherry	Maple kanadisch	white B3002 LP	light grey L4058LP	Oak 328DNTL	Ash M3955NTL	Maple M2106NM	Beech- M112NM	Walnut M4462NM	Cherry M760NM	Acacia M4451NTL	Thermo M6222NTL		
Micro	2/2/0.5		✓	✓	✓				✓	✓	✓	✓	✓	✓	✓	✓	✓	✓	✓		
Micro	3/3/0.5		✓	✓		✓	✓		✓	✓	✓	✓	✓	✓	✓	✓	✓	✓	✓		
Clou	8/8/1.2		✓	✓		✓	✓		✓	✓	✓	✓	✓	✓	✓	✓	✓	✓	✓		
Clou	8/8/2																				
T	16/16/10-3		✓	✓		✓	✓	✓	✓	✓	✓	✓	✓	✓	✓	✓	✓	✓	✓		
T	16/16/10-4																				
T	16/16/10-5			✓					✓	✓	✓	✓	✓	✓	✓	✓	✓	✓	✓		
M	16/16/6																				
M	16/16/8																				
M	16/16/10																				
M	16/16/10																				
M	20/20/8																				

  

		eco										eco									
		white RAL 9010	Beech steamed	Maple european	Birch	Oak european	Am. Walnut	Am. Cherry	Maple kanadisch	white B3002 LP	light grey L4058LP	Oak 328DNTL	Ash M3955NTL	Maple M2106NM	Beech- M112NM	Walnut M4462NM	Cherry M760NM	Acacia M4451NTL	Thermo M6222NTL		
6/2 M	7%																				
8/3 M	19%																				
9/2 M	6%																				
9/2 HR	6%																				
13/3 M	12%																				
12/4 M	15%																				
14/2 M	7%																				
19/2 M	6%																				
28/4 M	7.5%																				
29/3 M	6%																				
30/2 M	3.5%																				
Typ R																					

... more than 250 different samples available immediately from our stock! Special samples within 2 weeks + shipping (nominal charge)

### VISIT OUR PLANT IN LUNGERN

Our company headquarters and the Production site in Lungern are 30 minutes south of Lucerne, accessible by rail or road.

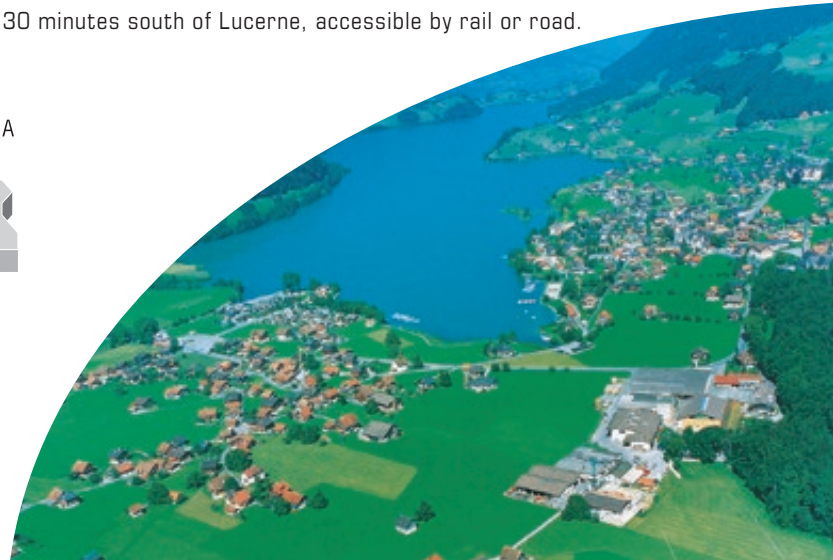



MORE INNOVATIVE  
DESIGNS AT  
[WWW.TOPAKUSTIK.COM](http://WWW.TOPAKUSTIK.COM)

TOPAKUSTIK®  
IS A BRAND OF:

NH AKUSTIK + DESIGN AG  
OBSEESTRASSE 11  
6078 LUNGERN  
SWITZERLAND

[CONTACT@TOPAKUSTIK.COM](mailto:CONTACT@TOPAKUSTIK.COM)  
[WWW.TOPAKUSTIK.COM](http://WWW.TOPAKUSTIK.COM)  
T +41 41 679 73 73

  **intextur**

2019/2020 EDITION  
SUBJECT TO CHANGES  
© TOPAKUSTIK  
Printed in Switzerland on FSC-Mix Paper

DISTRIBUTED BY:

SGB ACOUSTICS LLC  
d/b/a **TOPAKUSTIK® USA**  
1718 REMINGTON DRIVE  
CROFTON, MD 21114  
PHONE 1 410 849 4333  
[info@topakustikusa.com](mailto:info@topakustikusa.com)  
[www.topakustikusa.com](http://www.topakustikusa.com)

